

**PERSAX**<sup>®</sup>  
feel the space

# CORPORATE CATALOGUE

COMPANY - PHILOSOPHY - PRODUCTS



# PERSAX UP TO TODAY

In 1976, PERSAX S.A. was born as a result of the merger of several roller shutter firms which had been in this industry since the 1950's. The new company began extruding PVC profiles, an area which would become one of the main pillars of the firm and a real reference in the market.

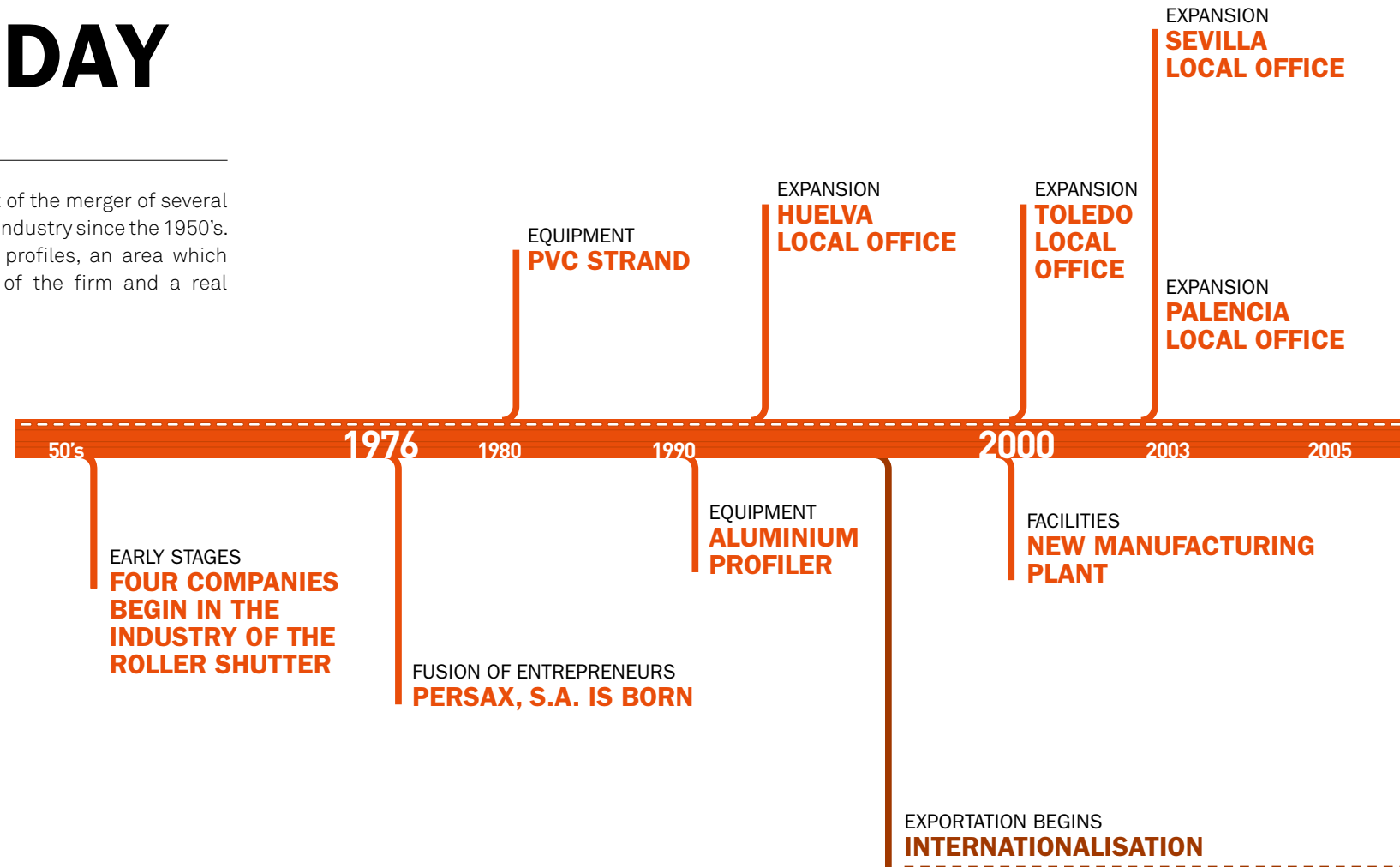

INTERNATIONAL EXPANSION  
**SUBSIDIARY  
IN MEXICO**

EXPANSION  
**VALENCIA  
LOCAL OFFICE**

2006 2008 2009 2016 2018

INTERNATIONAL EXPANSION  
**SUBSIDIARY  
IN CROATIA**

**PRESENCE IN MORE THAN 40  
COUNTRIES**



# THE FIVE PILLARS OF PERSAX

---

To offer quality solutions, tailored to the client, with An excellent service-oriented attitude to meet the needs in solar and security protection.



## 01 | INNOVATION

Persax has a RDI Department, composed by a team of engineers and architects who, by constantly analysing the market trends, carry out important research and product innovation tasks.



## 02 | QUALITY

We pay special attention to the traceability of all our production process, from the order to the delivery.



This is all done according to the strictest quality controls required by the ISO 9001 international standard.

## 03 | SUSTAINABILITY

Sustainability and respect for the environment are concepts linked to our products from the very beginning: insulation, energy-saving and energy efficiency are terms that define the advantages of its use.

## 05 | INTERNATIONAL

Internationally, our marketer spirit started during the decade of 1980, with the expansion into neighbouring Portugal, France or Northern Africa.

In the 90's, we began our journey into countries of Latin America (Uruguay, Chile, Argentina, and Brazil).

The internationalisation process culminated in 2000 with the opening of our two international delegations in Mexico and Croatia, and an important customer portfolio across different continents.

## 04 | CUSTOMER SERVICE

For Persax, client contact is essential. We offer a customer service thanks to which we are able to solve any eventuality.

# OUR FACILITIES

Our production is carried out 100% in our headquarters in Alicante. This allows us a complete control of the production process and an absolute control over quality.

This centrality means a greater response to customer needs.

All our products meet all requirements and standards required in the different markets in which we are present, ensuring maximum levels of insulation, comfort and energy saving.

## PVC EXTRUDERS

Our advanced technology stands out in our PVC extrusion (for slats, boxes and guides) products.



## ALUMINIUM PROFILERS

---

Five aluminium profilers make up our section of profiling. All types of slats with polyurethane are manufactured there. These guarantee acoustic and thermal insulation.



## MANUFACTURING

---

We manually manufacture all our products, paying special attention to details.

Our facilities have a dedicated area for manufacturing solar protection elements. Our fabric stock allows us to quickly meet the needs of our customers.

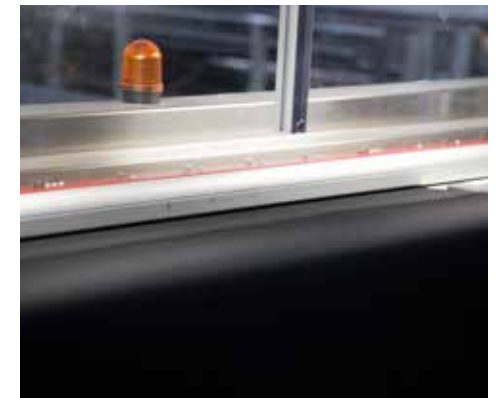

# LOGISTICS AND OPERATIONS

By means of direct distribution and local offices, since the foundation of the company, as well as a sales network and our own transport fleet.

Persax maintains a close relationship with its customers and ensures the highest quality and speed of service.







# RDI AND CERTIFICATIONS

To fulfil our mission, Persax has a RDI Department composed by a team of engineers that, by constantly analysing the market trends, develop great research and product innovation tasks.

Special care is placed on quality, which is seen both in the raw materials and the technology used in our production processes.

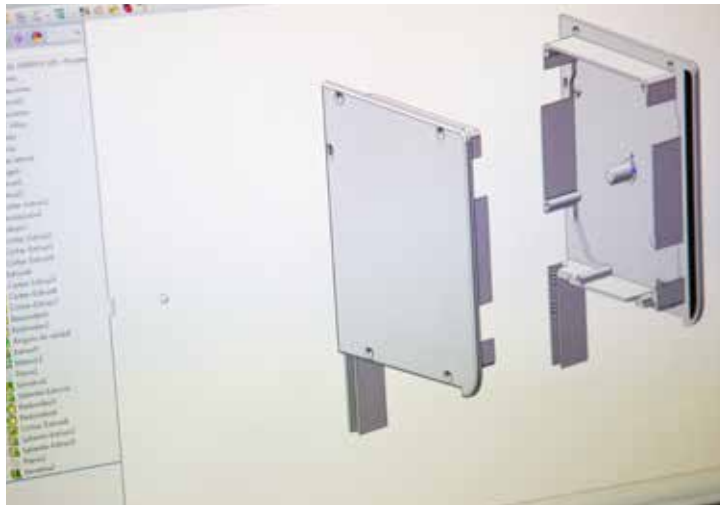
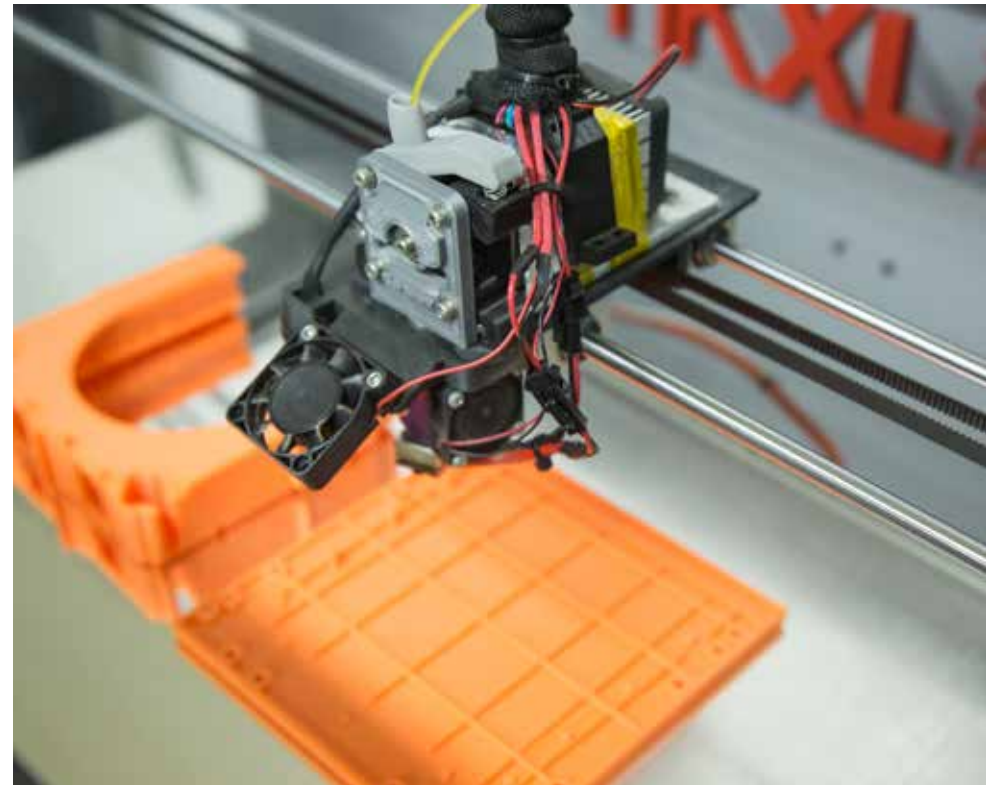

## NATIONAL AND INTERNATIONAL CERTIFICATIONS

Persax guarantees the traceability of its entire production system. From the moment the order is made to its delivery, the process is guaranteed by AENOR with the ISO 9001 international certification (IQNET).

In addition, our products are subjected to several tests, such as Resistance to wind loads, Thermal transmission, Acoustic isolation and Water permeability tests, among others.

Thanks to this we can certify the proper operation of our systems.

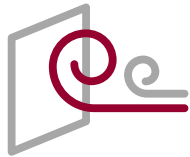

# ROLLER SHUTTERS

Roller shutters become an important element at home, not only as a protection element but also as a distinguishing factor when trying to make more responsible energy consumption, since they offer:

- Protection of the windows against damages caused by strong winds and heavy rain.
- Prevention against damage to the fabrics inside the house caused by intense solar exposure.
- A physical barrier that acts as a deterrent against intruders.
- Total privacy when the shutters are closed.
- Partial or total regulation of the entry of sunlight into the house.
- Easy maintenance and high durability.
- Self blocking models provide your home with an extra security measure.

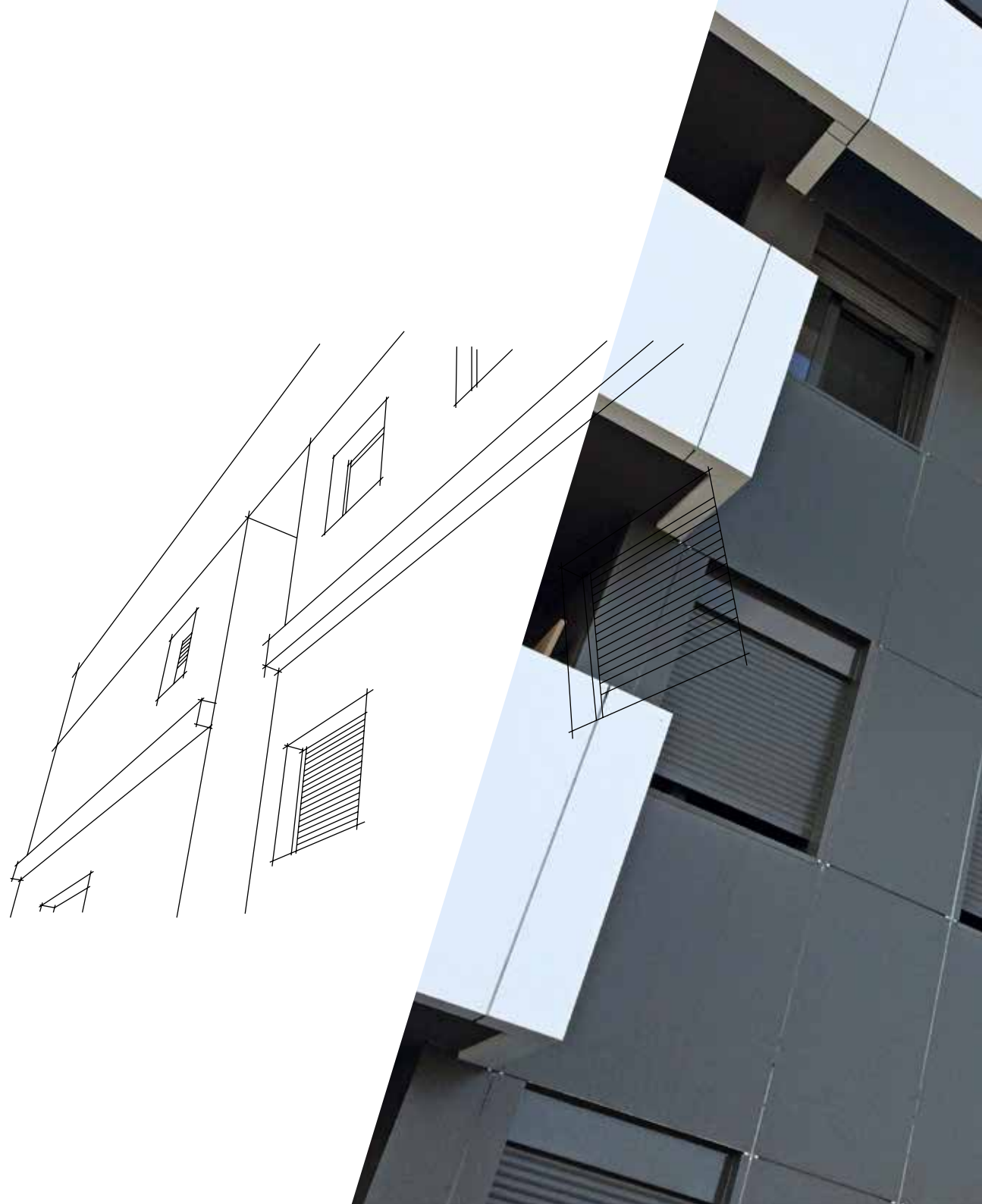

## FOAM FILLED ALUMINIUM SLATS

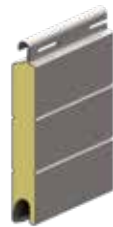

<b>Micralum 39</b>
Max width   2,30m

<b>Minisax 40</b>
Max width   2,00m

<b>Minicur 43</b>
Max width   2,90m*
Max width   2,50m

<b>Termisax 45</b>
Max width   3,00m

<b>Termilum 45</b>
Max width   2,20m

<b>Termicur 45</b>
Max width   3,00m*
Max width   2,80m

<b>Termicur 55</b>
Max width   4,50m

\*High Density

\*High Density

## EXTRUDED ALUMINIUM SLATS



<b>Minisegur 40</b>
Max width   3,00 m

<b>Segur EC60</b>
Max width   4,00 m

<b>Blockalum 39</b>
Max width   3,00 m

<b>Blockalum 45</b>
Max width   3,50m

## PVC SLATS



<b>Aragón</b>
Max width   1,80 m

<b>Berna</b>
Max width   2,00 m

<b>Paris</b>
Max width   2,00 m

<b>Sevilla</b>
Max width   1,80 m

<b>L-37</b>
Max width   1,50 m

<b>C-42</b>
Max width   1,70 m

<b>L-50</b>
Max width   2,00 m

## DIFFERENT WAYS OF INSTALLATION

Persax offers three different systems, each responding to different construction needs.

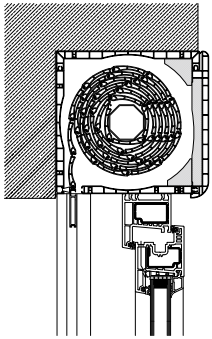

THE COMPACT SYSTEM is the most popular in the market. The shutter head box is placed just above the window, creating a compact block that simplifies installation. Moreover, it facilitates the access to inside mechanisms for maintenance and repairs. It rolls the shutter “internally”.

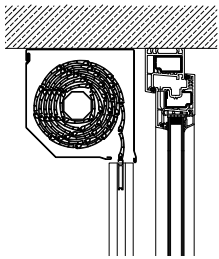

MINI SYSTEM or renovation system is designed to allow the installation of a shutter over a previously existing window without a shutter or to avoid the need to carry out brick works, or even just to avoid removing the existing window. The head box is not placed above the window fitting, but is installed on the outside, in front of the window or on the façade, simply and with hardly any brick works./ It rolls the “outer” shutter.

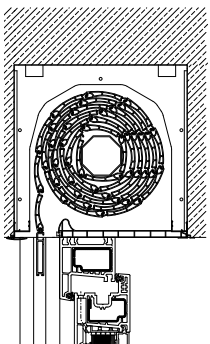

TUNNEL SYSTEM / BUILT-IN SYSTEM, It is designed to remain completely hidden in the building. Once the installation is finished nothing can be seen inside or outside the building. It allows obtaining high levels of both thermal and acoustic insulation. Depending on the way of installation the shutter rolls inside or outside.

## ACTIVATION SYSTEMS

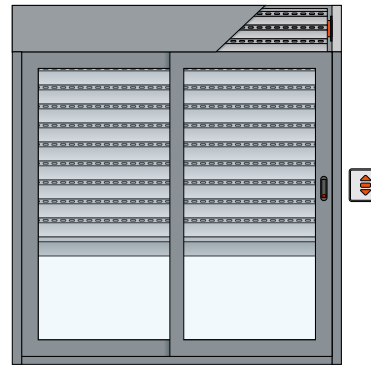

MOTOR

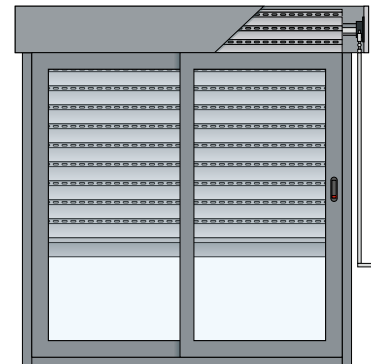

GEAR

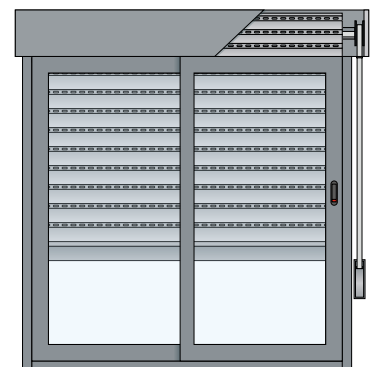

COILER

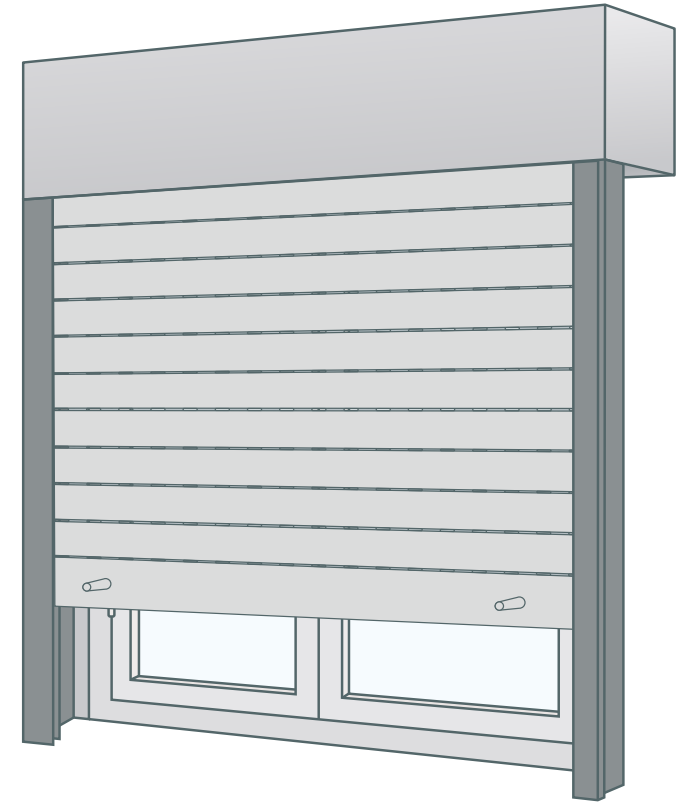

## ENERGY PREMIUM

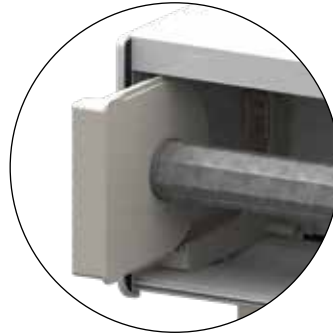

Removable System (Premium accessories)

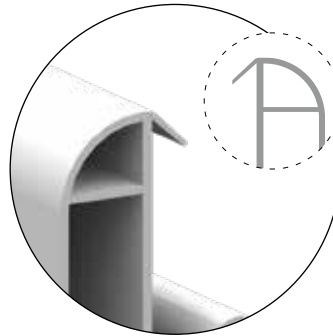

Insulation flap (sealing to water coextrusion)



Expanded polystyrene insulating

### Removable system

The new Energy box allows maximum comfort and a greater energetic efficiency with a reduction in energy costs.

Its U heat transfer coefficient=  $1,2 \text{ W/m}^2\text{k}$  is one of the best insulation values in the current market and it prevents cool and hot air leaks at home.

Its Class 4 Permeability to air and 3000Pa wind pressure resistance provide insulation in strong air conditions.

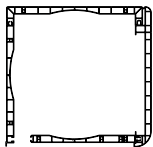

155 - 185 - 200



## PVC STANDARD

---



Removable System (Premium accessories)

### Sizes versatility

Persax Standard box meets the need of a box compatible with most of the metal works systems in the market.

The quality of PVC used in the manufacturing process is well recognized by our customers, and so is the thickness of the profiles, all of which provides the window with a better thermal and acoustic insulation. Furthermore, the Standard Box is also available in a Premium version that makes use of removable plates to facilitate access to the inside in a quick and comfortable way.

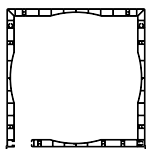

155 - 185 - 200 - 225





## MAX

---

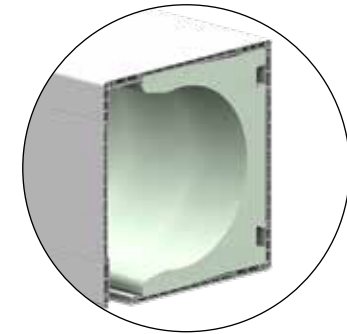

Triangular insulating  
(expanded polystyrene)

### Big surfaces

The new Max shutter box, consisting of 4 PVC profiles, is the perfect solution for large roller shutters.

The two sizes in which it can be manufactured allow a tighter rolling of the slats, which is perfect for large spaces.

The option for lacquer enables excellent integration with any colour in the pre-existing metal work.

The possibility of including expanded polystyrene provides a better thermal and acoustic insulation.

## **MINI SYSTEM**

---



Outdoor view



Indoor view



### **The perfect choice for already installed windows**

When installing a box in a previously installed window, Mini system provides the following advantages:

- It does not require any work inside the home because all the mechanisms, except for the strap and the coiler, are placed outside
- Easy installation, since it is placed directly on top of the window
- No need for brick work
- Inexpensive system
- Possibility to add a rolling mosquito net inside (only available in 2P 45° aluminium box: 165 and 180)



## TUNNEL BOX

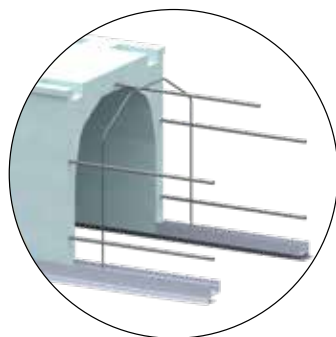
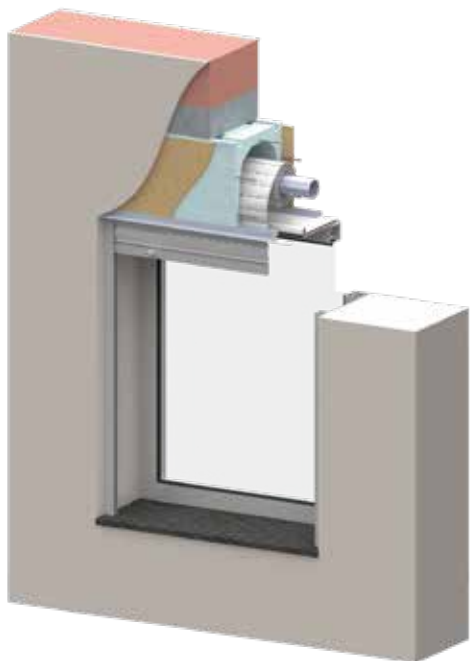

Inner reinforced structure

### The evolution of the traditional built-in box

The new Tunnel box is the evolution of the traditional built-in box.

Thanks to the peculiarity of its expanded polystyrene structure, the Tunnel box provides excellent thermal and acoustic insulation. Furthermore, its special structure embedded into the wall allows it to be hidden from view.

Another advantage is its roller up capacity, which makes it especially indicated for large shutters which are not normally compatible with traditional boxes.

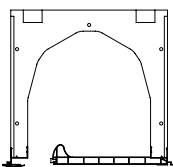

25x25 - 28x30 - 30x30



# ROLLER SHUTTER DOORS

PERSAX offers a wide range of roller shutter doors adapted to every need, from the most extreme security to the most economical option.

- Among the rolling shutters, the self blocking systems stand out, as they provide extra protection against burglars.
- We have incorporated a state of the art dying system by sublimation which allows choosing unique images for your business that also incorporate anti-graffiti protection.



## SELF BLOCKING ALUMINIUM SLATS



**VS-150 Block 60**

Max width	4,50 m
Max width extreme	6,50 m

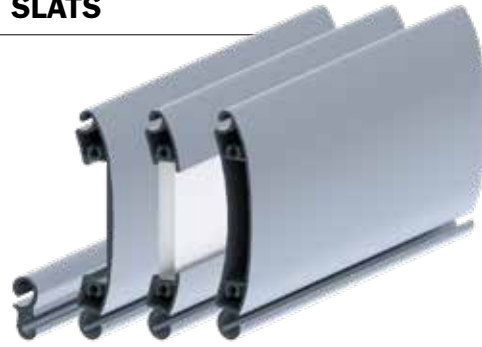

**VS-300 Block 95**

Max width	4,50 m
-----------	--------

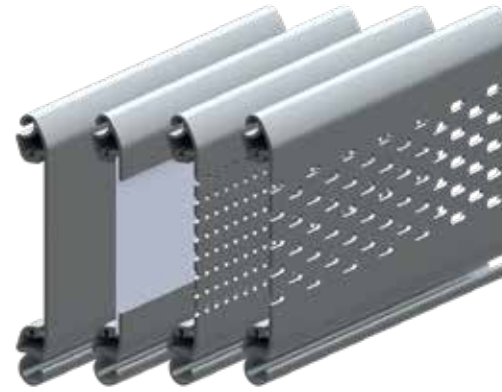

**VS-350 Block 110**

Max width	4,50 m
-----------	--------

## FOAM FILLED SLATS

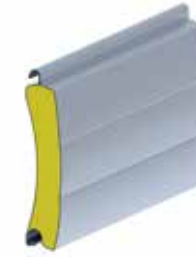

**V-77 PF**

Max width	3,50 m
-----------	--------

## EXTRUDED ALUMINIUM SLATS



**EC-60**

Max width	3,00 m
Max width extreme	4,00 m



**V-77**

Max width	4,50 m
-----------	--------



**V-80**

Max width	5,50 m
-----------	--------



**V-100**

Max width	4,50 m
-----------	--------

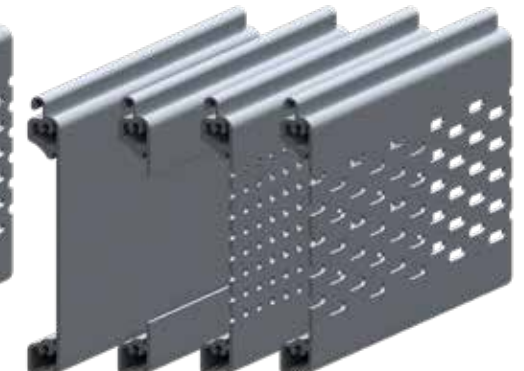

**V-10**

Max width	4,00 m
-----------	--------

# EXTREME SYSTEM

Our security system EXTREME is especially suitable for areas requiring extra security due to high burglary rates or extreme weather conditions. It can resist hurricane winds of over 220 km/h.

Compatible with VS-150 Block-60 and Segur EC-60 slats, the Extreme system consists of a special end cap and guide that provide extra strength and security to whole roller shutter door system.

- Extreme security, the VS-150 Block-60 system is also self-blocking.
- Able to resist winds over 220 km/h (VS-150 Block-60).
- I also can lower the amount of your home insurance policy.

Pressure exerted by the wind or during an attempted theft

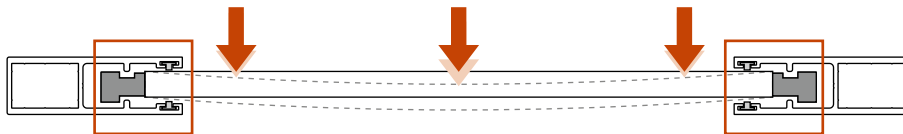

The end caps, together with the guide, prevent the slat from being released

SECURITY

RESISTANCE





Persax EXTREME system was awarded the first prize in the category in the Awards by the “Nan Arquitectura y Construcción” magazine.

EXTREME won in the category for Materials and that for Construction works in wood, metal, PVC and glass thanks to its raw quality, features and top-notch security levels.

Salvador Ochoa, Manager at Persax, had the privilege of picking up the award, recognising when doing so the great job all his team carries out, and their perseverance in achieving quality products that are always one step ahead in the market.

These awards are divided into two different sections: one for projects, composed of 6 categories, and another for construction materials, divided into 11 categories. The spokesperson for the jury was the President of the “Consejo Superior de Colegios de Arquitectos” of Spain, Mr. Jodi Ludevid, who, at the end of the event, awarded the Honorific Award to the prestigious architect Francisco “Patxi” Mangado.



# MOSQUITO NETS

We all like enjoying fresh air especially during summer season, the problem is the unpleasant presence of insects that make us close different rooms to keep them out.

Persax mosquito nets will help you to protect your home from insects and allow you to have doors and windows opened.

- **Wide range of models that can be adapted to all needs, from traditional systems, such as fixed and sliding mosquito nets, to rolling mosquito nets or the state of the art chain pleated and chain rolling nets.**
- **We offer a variety of finishes, from the traditional standardized RAL chart, to a range of laminated wood-like finishes, all of which allow for a perfect integration of the mosquito net with any wood or metal work.**
- **The standard net 18x60 made in fibreglass for the best protection against insects is ideal for traditional protection. The colours are very durable and the net will not suffer deformation.**





## PLEATED MOSQUITO NETS

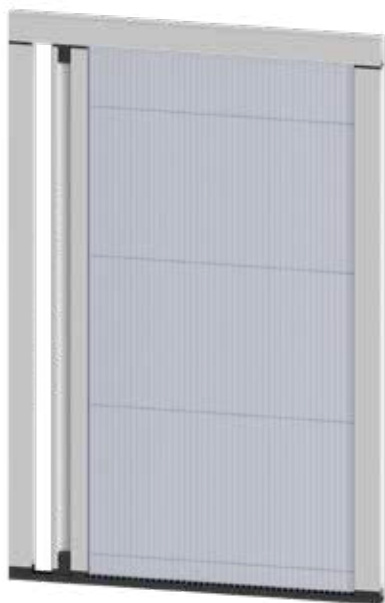

### 18 mm pleated

Perfect for reduced installation spaces

Very versatile, it allows assembling in large opening such as doors or way out to balconies and terraces and also in small gaps such as windows.

The fabric composition made of threads makes it quieter and gives an aesthetic hint. Its reversible option allows both side positions to give more comfort to users.

18 mm pleated	
Max width	2,80 m (double sheet)
Max height	2,60 m



### 40 mm pleated with chain

Easy opening and the possibility of placing it in any position with no intermediate stop. The folding system of the fabric using a chain allows a free space with no obstacles when the mosquito net is put aside.

It allows to cover large areas, up to 3 metres high and unlimited width and makes it possible to use it in all kind of terraces.

Easy assembly, the use of fixing plates enable the whole mosquito net to be contained into a cassette clipped to these plates thus making it easy to remove.

40 mm pleated with chain	
Max width	2,90 m (single sheet)
Max height	3,00 m



## ROLLING MOSQUITO NETS



### C42 and C35 Rolling mosquito nets

This operates with the help of a spring that allows the fabric to be recovered. Thus the tissue is guided on both sides and secured at its lower part by means of hooks.

It is an easy, practical and comfortable system that makes it possible to replace tissue damaged by use.

Recommended for all kind of spaces especially for folding windows.

Easy assembly, use and maintenance it allows to keep the tissue safe when it is not used.

As a novelty, Persax offers the telescopic spring system option, which allows fixing the mosquito net without screwing, making even more easy its assembly.



Rolling	C42	C35
Max width	2,00 m	1,50 m
Max height	2,30 m	1,70 m

## ROLLING MOSQUITO NETS



### M16 rolling with chain

Persax offers the new lateral rolling mosquito net M16 with chain which joins the functionality of the rolling one with the comfort of the system with chain.

Specially indicated when covering large openings without the disadvantage of the fabric coming out of the guides.

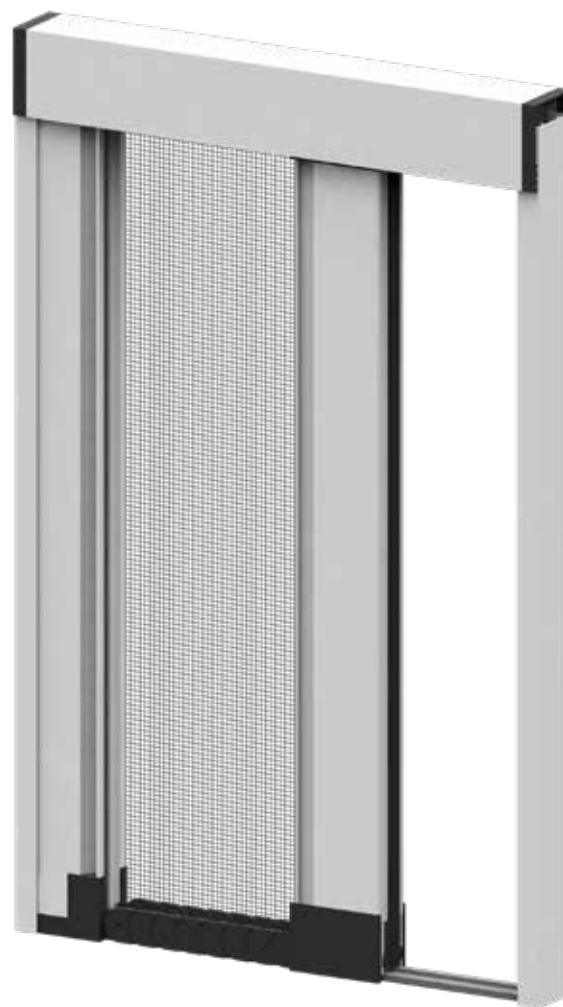

Rolling mosquito nets	
Max width	2,80 m (double sheet)
Max height	2,50 m





## FIXED AND SLIDING MOSQUITO NETS

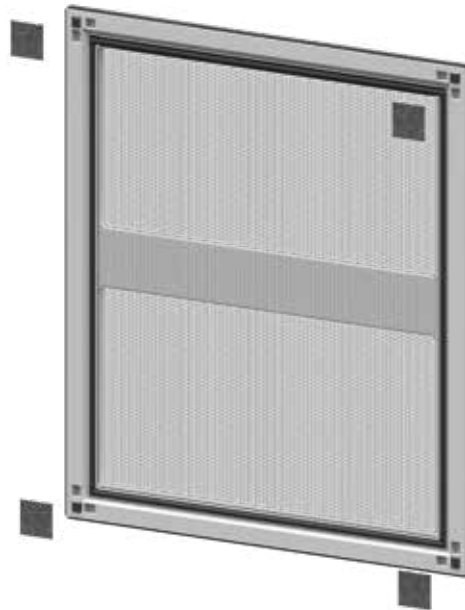

### Fixed

This is the best economic and simple solution for sliding doors or Windows being assembled and operated from inside.

It remains fully integrated into the woodwork adapting to the space and covering it all.

The use of magnets (option) allows an easy installation of the mosquito net avoiding the presence of screws.

Fixed	
Max width	1,20 m
Max height	2,00 m



### Sliding

It is recommended when there isn't enough space or the exit is rarely used.

It is a simple, economic and long-lasting system that allows to replace the tissue at a low cost.

The great variety of special profiles and sealing brushes provide solution in difficult spaces .

A wide range of colours including standard RAL, Wood lacquered and coating finishes.

Sliding	
Max width	1,20 m
Max height	2,00 m

## FOLDING MOSQUITO NETS



### Folding

It is recommended for outside doors that open from inside. The best solution in the way out to balconies, terraces and entrance and exit areas.

It consists of one or two folding leaves on a fixed frame secured to the space. The appearance and profiles look like aluminium frames.

This mosquito net with a system of hinges with a recovery spring becomes the best solution when people with reduced mobility, elderly people or children. The magnetic system allows the frame and leaf being joined together in an invisible and effective way with no maintenance or further adjustments.



Folding	
Max width	1,00 m
Max height	2,20 m

# AWNINGS AND PERGOLAS

Persax offers a variety of systems that respond to all the market's sun protection needs, paying special attention to aesthetics, from classic, traditional styles to modern, current trends.

Metallic and lacquered finishes in conjunction with awning fabrics in a multitude of colours and prints give the finishing touch to your facade or terrace, creating a unique space.

- Reduces the temperature by up to 9°C inside the house.
- Reduces the electricity demand of air conditioning by between 30% and 50%.
- Reduces the solar radiation that reaches the interior of the home by up to 80-90%.
- Dramatically reduces the thermal transmission (U factor) of the building, with awnings and shutters providing greater efficiency than windows.

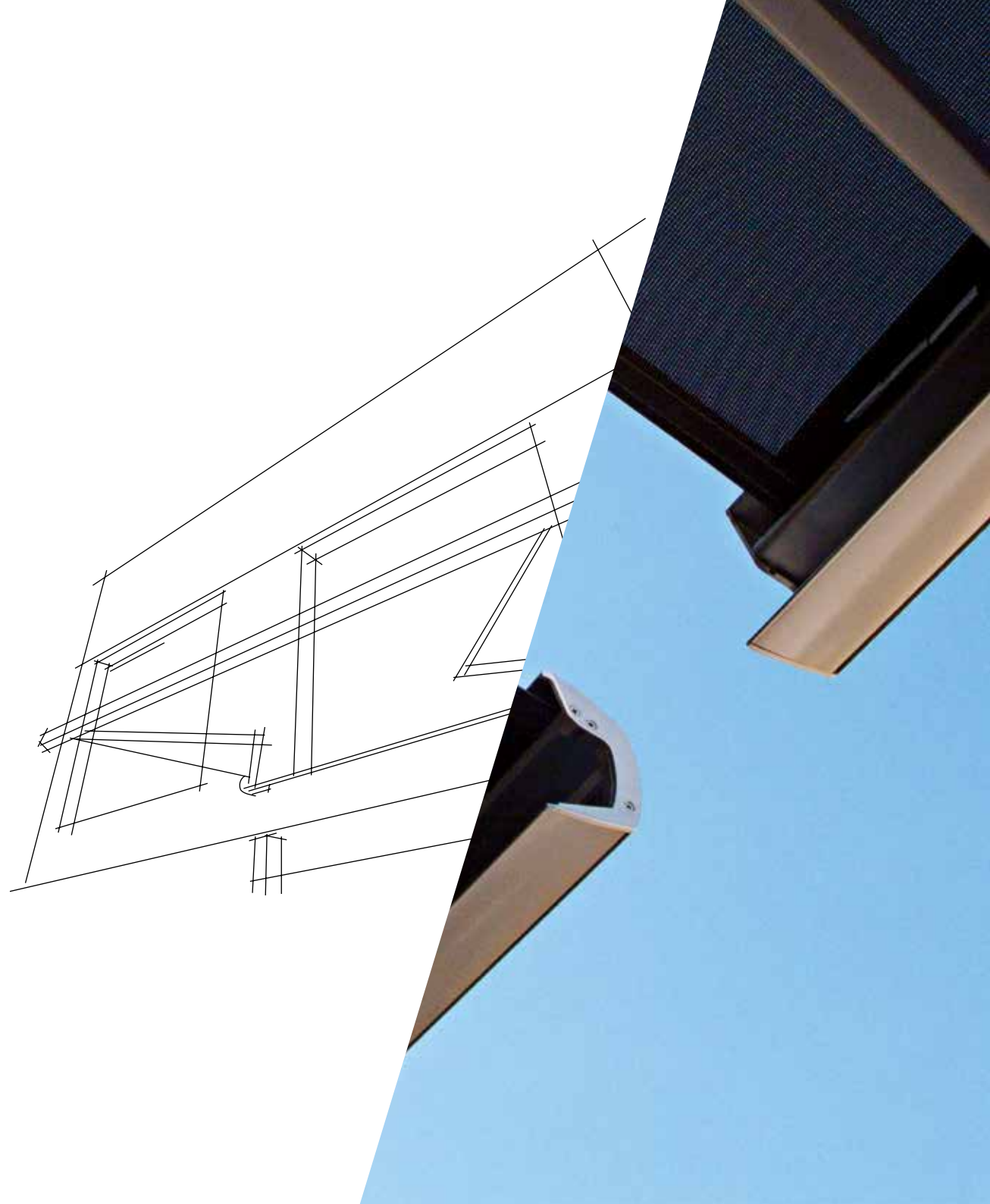



## HIDRA, MILOS AND TASOS BOXES

Cassettes are the most modern system for your terrace.

In addition to the attention to detail and finishing touches, both the fabric and the mechanical elements of the awning are fully retracted and protected against bad weather, which increases the useful life of the product.



Boxes	Hidra	Milos	Tasos
Max width	4,00 m	6,00 m	7,00 m
Max projection	2,50 m	3,00 m	4,00 m



## MONOBLOCK SAMOS Y SIROS

This system permits the regulation of the angle and position of the arms in the workshop, thus decreasing the time taken to install the awning on-site.

The brackets are fitted on a square 40x40 mm bar, which means the arms can be displaced or centred easily to the desired distance and two or more arms connected.

There is a semi-cassette version for greater protection of the fabric when the awning is retracted.



Monoblock	Samos (and semibox)	Siros
Max width	6,00 m	6,00 m
Max projection	6,00 m	4,85 m



## INVISIBLE ARMS

This system is based on two extendible arms that remain just below the awning, allowing a high level of mobility around the installation, with no obstacles. Its versatility means wall, ceiling and side fixings are all possible.

Adaptable to almost any environment. The different varieties of this model mean it can suit all needs. Mainly indicated for balconies, chalet terraces and especially shops.

There is a semi-cassette version for greater protection of the fabric.

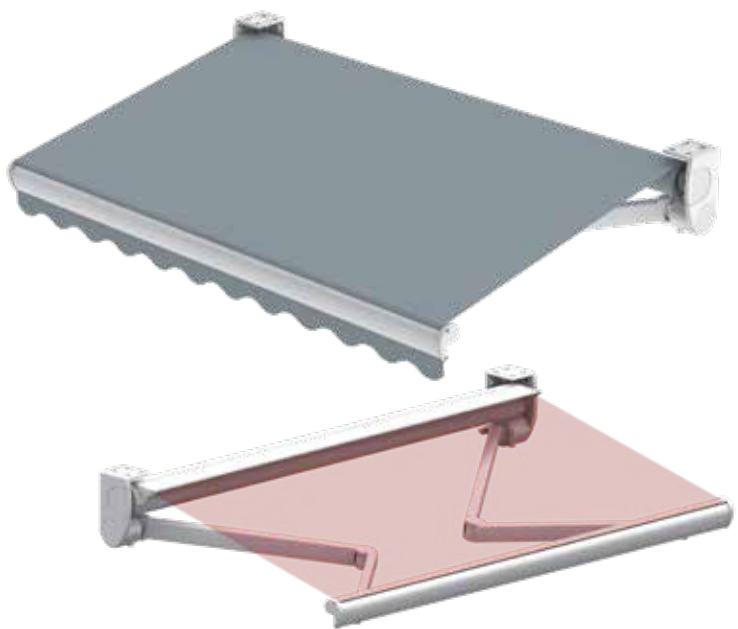

Invisible arms	Rodas 250	Rodas 350	Semicassette
Max width	4,00 m	6,00 m	5,00 m (350)
Max projection	2,50 m	3,50 m	3,00 m (350)



## STORE AND DROP ARMS

The classic systems on the market. You can simply and economically protect any type of window or access to balconies and terraces.

Its main advantage is that the angle can be regulated as the user wishes, up to 180°, and can thus cover the whole window.

The Estor awning is an ideal system for balconies and small spaces. It works by fixing the arms to the hand rail with two possible positions, one fully vertical and other projecting outwards away from the facade.

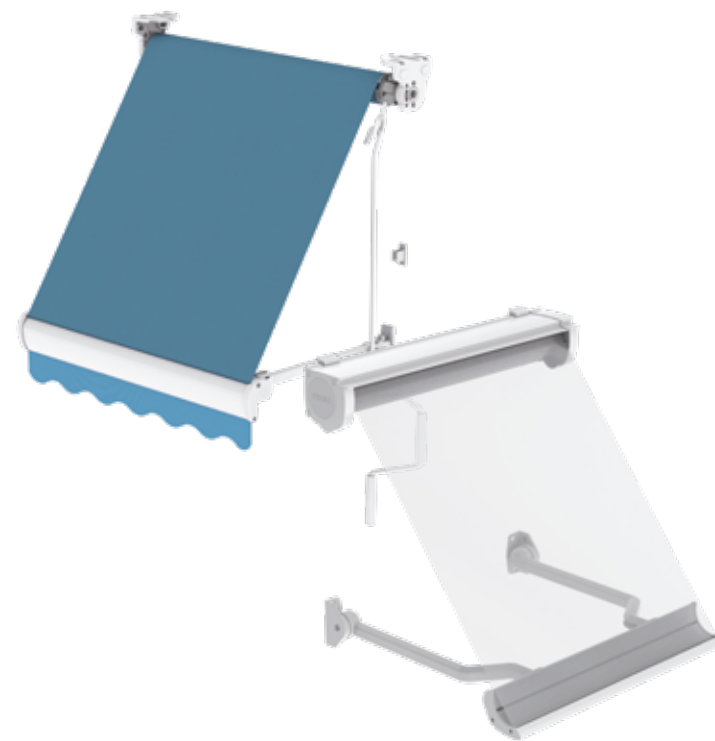

	Drop Arms	D. Arms Box	Store	Store Box
Max width	6,00 m	5,00 m	6,00 m	6,00 m
Max projection	3,00 m	2,50 m	1,40 m	1,20 m

## PERGOLAS

This is one of the more classic and elegant ways of protecting from the sun in spacious areas such as gardens, large patios, swimming pools, restaurants, etc.

Versatile system that is easy to install on irregular surfaces thanks to its simple shapes and the large amount of compatible and interchangeable parts.

Its style is characterised by the purity of its lines, in keeping with the most current trends in architecture and design, resulting in balanced and elegant environments.



Pergolas	Standard	Karpatos
Max width	5,50 m	6,00 m
Max projection	5,50 m	6,00 m



## BIOCLIMATIC PERGOLA UMBRA

Umbra is a system for bioclimatic pergola which allows enlarging any outdoor living areas without the need for brickwork, thus becoming the perfect solution for terraces, gardens, hotels and restaurants.

Thanks to the possibility of motorization and numerous sensors, which detect any unfavourable weather conditions, it allows you to enjoy your outdoor area during the entire year.

Moreover, it can incorporate a wide range of comfort elements (LED lights, music, heating, etc.) which can be controlled with one of the remotes or any multimedia device, such as Smartphone or Tablet.



Umbra is waterproof, made in motorized aluminium slats that can be easily oriented, and, thanks to their flexibility, they allow a natural regulation of the temperature in the area, as well as offering protection against sunlight, rain, wind or any other weather condition.

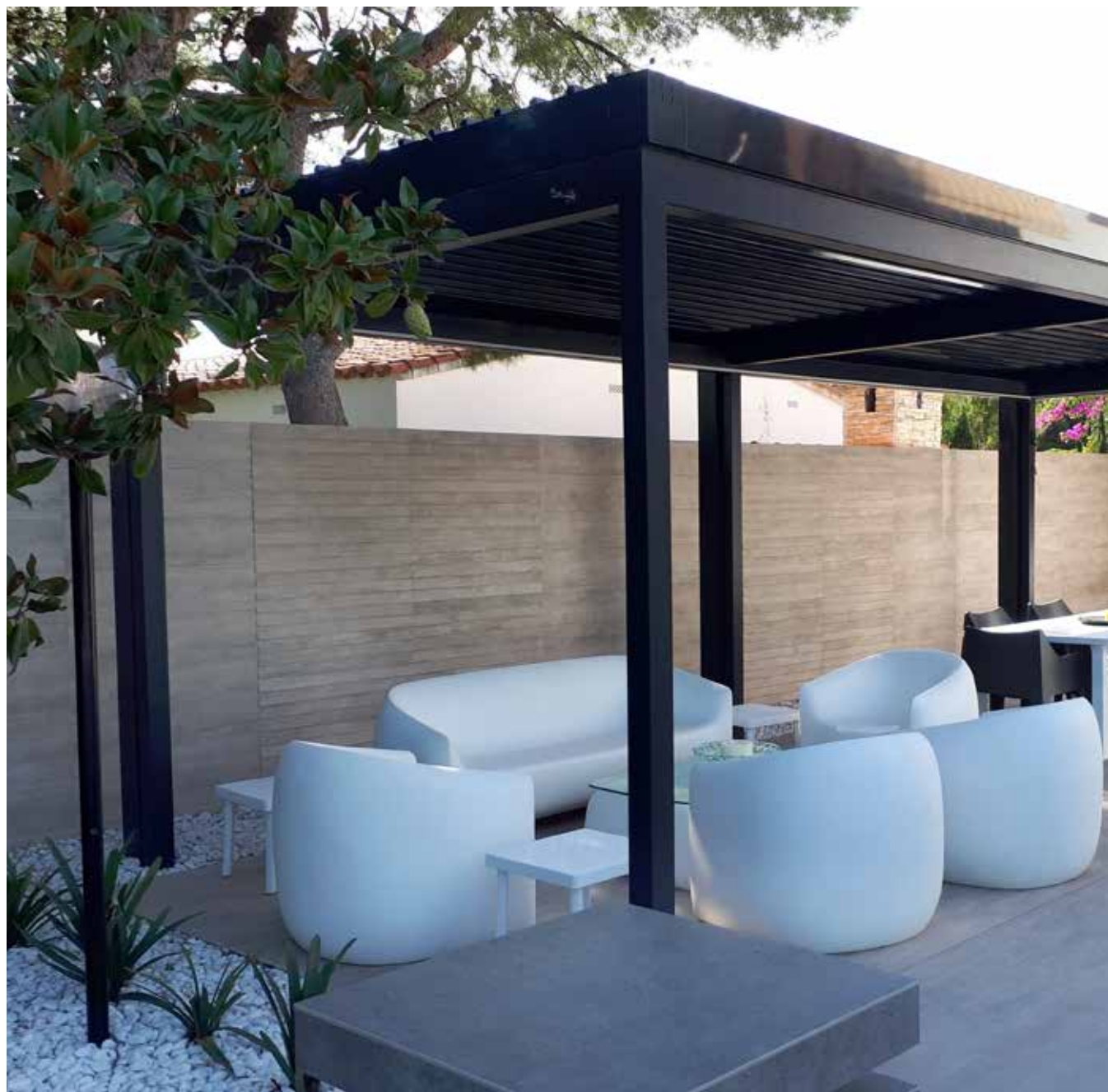



Pergola	Umbra
Max width	4,00 m
Max projection	6,45 m

# DECORATION

Persax presents its new decoration line. A collection that includes almost 300 models in a varied colour-scheme and style, from natural and ecological fabrics, free of harmful chemical agents, to the most up to date fabrics, both in technology and design. Wide range of options both for roller curtains and sliding panels.

The main characteristic of this brand new line of technical fabrics by Persax is their technology. They are made in natural, ecological fabrics, free of harmful agents, allergens and with anti-bacteria treatment; these fabrics combined with the creation of a comfortable and attractive space can, therefore, improve the well-being at home.

- **The new collection of technical fabrics by Persax offers different heat insulation capabilities and great fire protection ability.**
- **Wide range of nature-inspired tonalities and textures, from the most natural and rustic fabrics, to the most up-to-date designer fabrics; they allow us to adapt the design to any type of decoration.**
- **Our digital printing also allows the total customization of any fabric.**



## ROLLER CURTAINS

Nowadays, roller curtains are the most popular product among consumers. Therefore, PERSAX® has developed a very complete catalogue of fabrics that cater for any needs, both technical and quality wise and, of course, aesthetically.



Screen tissue made in fibreglass and polyester with PVC with different opening factors, Tevira fabric, 100% polyester, opaque, etc. all of them offer the highest energy efficiency, visual comfort and environmental quality.

We offer systems with an aluminium shaft in 25, 45, 58 and 80 mm diameters, which can be activated by chain, spring, handle or motor, thus allowing manufacture in the highest quality and the best finishes in the market.

Our great variety of fabrics and colours, as well as the possibility to customize your roller curtain with images by digital printing will help you find anything you are looking for.





## **VERTICAL CURTAIN**

---

PERSAX® vertical curtain in vertical slats, which can be 89, 127 or 250 mm wide, allows to fold the slats to the right, the left, both sides or the middle. This mobility and regulation of the slats allows a very practical control of the entry of sunlight.

It is available in 89mm aluminium slats, as well as in a wide range of fabrics and finishes, thus allowing for easy adaptation to any style in decoration.

It can be manufactured in angle, curves and different cuts of the slats, which makes it very easily to adapt to any space.





## SLIDING PANEL

PERSAX® offers Sliding Panels in three versions according to their folding method: rope, rod and motor; they can all be manufactured with rails with 2, 3, 4 or 5 tracks.

It is the ideal option to cover big windows and exit doors towards balconies, with straight designs, balanced with a minimalist character.

All our fabrics are compatible with this system, allowing for the combination of different models, colours and textures in one panel, thus creating an exclusive and unique atmosphere.

With its various opening possibilities, and the possibility to install two rails side by side, it can cover up to 12 lineal meters, thus allowing the division of the space. Moreover, digital printing allows us to offer total customization of your curtains into a unique feature.





## **VENETIAN CURTAINS**

---

Venetian curtains are the best available product in terms of sight and light regulation into the room. Made in a wide variety of styles and colours, they allow us to create an efficient and comfortable atmosphere.

Made in 16, 25 and 50 mm aluminium slats, or 50 mm Wood slats, PERSAX® offers a wide variety of colours and finishes, with total guarantee of the high quality of the materials.

The 50 system is available with ladder or ribbon finishes, which highlight the high quality of the product.

## **“ALICANTINA” CURTAINS**

---

This is the most traditional product of all which are sold by PERSAX®.

Apart from being an icon in the vast majority of towns, both in the Levante area and in the rest of Spain, these curtains offer extra protection in doors and Windows. They are made in wood and PVC and available in a wide range of colours to confer a personal and unique touch to your rooms.

They work in perfect harmony with other styles, and they provide excellent thermal insulation, needing very little maintenance.



## TERRACE CURTAINS

---

This is a very traditional product; this model was created to allow a nice air flow, while stopping unpleasant flies or mosquitoes from getting into your home and maintaining your privacy.

Made in different materials and finishes, you can choose the one that fits best with the style of your home. Beads, transparent ribbons, in one or two colours, rope in various braiding models or crocheted aluminium; we offer any variety that exists in the market nowadays.



## RUSTIC CURTAINS

---

The most traditional style. Rustic curtains create a rural atmosphere, while also providing an elegant style. They are made in round or flat wood sticks, in traditional or more modern colours, thus being easily adaptable to any decoration style.

The wood used for their manufacturing is always taken from controlled, reforested forests, which meet the requirements that PERSAX® sets for themselves in regards to environmental preservation.



# LOUVERS AND MALLORQUINAS

Persax Louvers are made in PVC or extruded Aluminium, thus achieving excellent results in all wind-resistance tests.

They allow for a flexible regulation of sunlight entry, which results in significant energy savings in the buildings.

Mobile louvers can be motorized when necessary.

Our louvers can be installed horizontally, as a curtain or vertically as a grille. The latter is ideal when it is necessary to prevent water from getting in.

- **Louvers offer sunlight protection and privacy.**
- **They can be installed as a wall wherever it is necessary to regulate the entry of sunlight, water and wind damage.**
- **In certain models (fixed) the lack of screws makes their installation very easy.**



## FIXED LOUVERS

Our offer of fixed louvers stands out thanks to its wide range of products, elegant shapes and broad diversity of applications, ideal for their installation in façade claddings, patios, terraces, marquee galleries, weather covers, etc. in addition to protection from the sun, the system gives spaces intimacy.



Afrodita

Atalanta

Atenea



Diana

Cibeles

Cibeles PVC

The fixed louvers can be made in PVC and aluminium, obtaining excellent results in the wind load resistance tests carried out at the Tecnalia laboratory, which is Class 6 in aluminium louvers and Class 3 in pvc louvers



## MOBILE LOUVERS

Thanks to the modern and practical design of the Tabarca and Costablanca slat profiles, an aesthetic finish and greater airtight closure are achieved. They are ideal as a sun protection system for facades. This slat system allows you to regulate light, achieving considerable savings in the interior air conditioning of buildings thanks to the creation of shaded areas that reduce the impact of sun rays reaching them.



**Tabarca AL 75**

Maximum width 1,30 m



**Tabarca PVC 71**

Maximum width 0,80 m



**Corablanca AL 150**

Maximum width 1,50 m



**Corablanca PVC 150**

Maximum width 1,10 m

## LEVANTE LOUVERS

Thanks to their elegant design, the Levante slat profiles can achieve spectacular results where the only limit is the architect's imagination. Perfect for façade claddings, they create an avant-garde style. Ideal for covering large glass surfaces, they can be fixed or mobile when it is preferable not to interfere with the view from inside.

The Levante louver is made in extruded aluminium, obtaining excellent results in the wind load resistance tests carried out at the Tecnalia laboratory, which is Class 6 in all its sizes.



Levante	120	210	300	400
Maximum width	1,30 m	1,50 m	3,50 m	4,20 m



## MALLORQUINAS

Persax has a line of mallorquinas of exceptional quality. All products are marked with the CE standard, in compliance with the highest quality standards. The systems manufactured are the folding system and the sliding system on rails.

Its adjustable mechanism has a steel mechanism which makes it 100% reliable. The treatment of all the aluminium alloy profiles offers guaranteed quality and makes the marquis outstanding products regarding virtues and advantages.

As they are made of aluminium, there is a wide range of RAL, anodised and lacquered wood finishes to choose from. In addition they adapt to any architecture and are easily and quickly assembled without any masonry work.



### Hinged

Maximum width	0,75 m (1 sheet)
---------------	------------------



### Sliding

Maximum width	0,75 m (1 sheet)
---------------	------------------



### Fixed

Maximum width	1,0 m
---------------	-------

# PERSAX<sup>®</sup>

feel the space

## CENTRAL OFFICES

Persianas Persax, S.A. · Autovía A-31 (salida 191) · 03400 Villena (Alicante) SPAIN  
P. 902 010 564 · P. 965 817 520 · P. Export. +34 965 272 444 · F. 902 010 565 · F. Export. +34 965 340 722  
export@persax.es · www.persax.com

## NATIONAL OFFICES

Valencia - P. 96 091 48 47 - F. 96 091 48 19 - info.valencia@persax.es  
Sevilla - P. 955 852 512 - F. 955 852 768 - sevilla@persax.es  
Huelva - P. 959 356 031 - F. 959 367 995 - huelva@persax.es  
Zaragoza - P. 976 855 336 - P. 976 854 833 - F. 976 859 161 - aragon@persax.es  
Palencia - P. 979 713 360 - F. 979 711 601 - castillayleon@persax.es

## INTERNATIONAL SUBSIDIARIES

Mexico - P. (669) 105.5010 - direccion@persax.mx / www.persax.mx  
Croatia - P. +385 1 3353500 - info@persax.hr / www.persax.hr

V. 1.0 (2018)

