

PERSAX[®]
siente el espacio

PUERTAS ENROLLABLES

ROLLER SHUTTER DOORS · PORTES ENROULABLES

PUERTAS ENROLLABLES



PUERTAS ENROLLABLES

Cuando adquirimos una vivienda o compramos un local, lo primero en lo que pensamos es en la decoración y el aspecto interior, pero es necesario que la seguridad de acceso sea la adecuada: Puertas, ventanas, persianas se convierten en los puntos más vulnerables.

Persax ofrece una amplia gama de puertas enrollables que se adaptan a cualquier necesidad, desde la seguridad más extrema, hasta las opciones más económicas.

EN ROLLER SHUTTER DOORS

When you buy a home or a commercial area, the first thing you think about is decoration and the interior appearance. But an appropriate access security is also necessary: doors, windows and shutters become the most vulnerable points.

PERSAX offers a wide range of roller shutter doors adapted to every need, from the most extreme security to the most economical option.

FR PORTES ENROULABLES

Lorsque l'on achète un logement ou un local, on commence toujours par penser à la décoration et à l'aspect intérieur, mais la sécurité de l'accès doit être appropriée : portes, fenêtres et volets roulants sont les points les plus vulnérables.

PERSAX offre une large gamme de portes enroulables qui s'adapte à tous les besoins, depuis la sécurité la plus extrême jusqu'aux options les plus abordables.

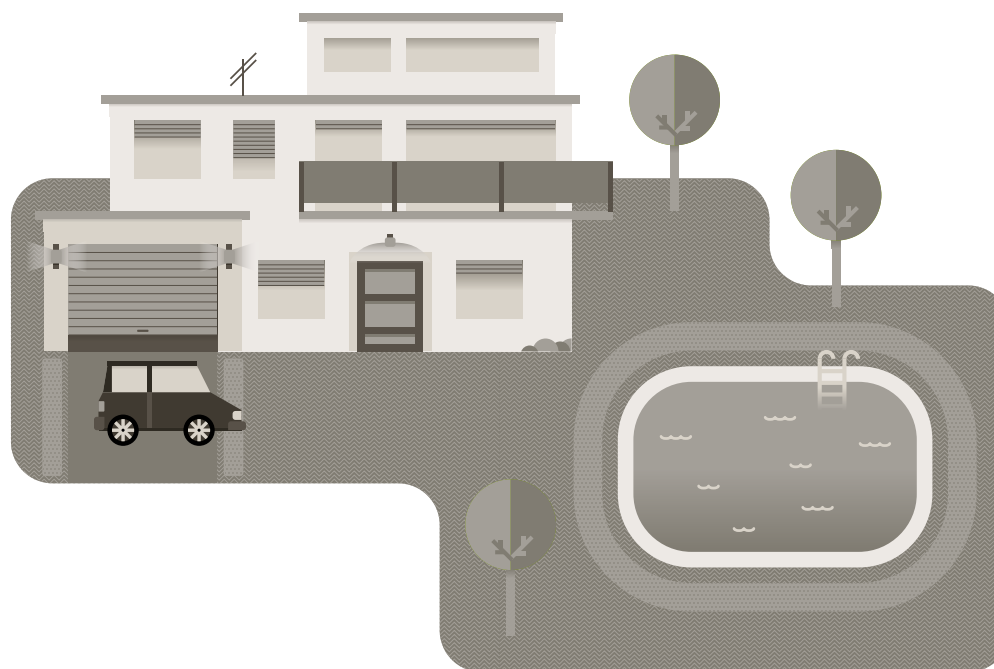



© Persianas PERSAX

Catálogo de Puertas Enrollables

Los datos de este catálogo son correctos salvo error tipográfico.

Persianas PERSAX se reserva el derecho de modificar cualquier dato o información recogida en ese catálogo sin previo aviso.

Última versión de nuestras tarifas, catálogos y folletos en nuestra web www.persax.es

Roller Shutter Doors Catalogue

All data explained are correct save typographic mistakes.

Persianas PERSAX se reserva el derecho de modificar cualquier dato o información de este catálogo sin previo aviso.

The latest editions of our price lists, catalogues and brochures in our webpage www.persax.com

Catalogues de Portes Enroulables

Sauf erreur de typographie, ces données sont correctes.

Persianas PERSAX a le droit de modifier toute donnée ou information de ce catalogue sans préavis.

Dernière version de nos tarifs, catalogues et brochures sur notre web www.persax.fr

ÍNDICE

6	PARTES DE UNA PUERTA ENROLLABLE
8	TIPOS DE INSTALACIÓN
10	FORMAS DE MEDICIÓN
12	GUÍA DE ELECCIÓN
14	PUERTAS AUTOBLOCANTES
20	PUERTAS DE ALUMINIO DE EXTRUSIÓN
28	PUERTAS DE ALUMINIO PERFILADO
30	CAJONES PARA PUERTAS
32	SISTEMA EXTREME
34	IMPRESIÓN POR SUBLIMACIÓN Y ANTI GRAFITI
37	FICHAS TÉCNICAS
64	GLOSARIO DE SISTEMAS

INDEX

6	PARTS OF A ROLLER SHUTTER DOOR
8	TYPES OF INSTALLATION
10	WAYS OF MEASUREMENT
12	HOW TO CHOOSE
14	SELF-BLOCKING ROLLER SHUTTER
20	EXTRUDED ALUMINIUM DOORS
28	FOAM FILLED ALUMINIUM DOORS
30	BOXES FOR DOORS
32	EXTREME SYSTEM
34	ANTI-GRAFFITI SUBLIMATION PRINTING
37	TECHNICAL DATA SHEETS
64	SYSTEMS GLOSSARY

INDEX

6	COMPOSANTS D'UNE PORTE ENROULABLE
8	TYPES D'INSTALLATION
10	PRISE DE COTES
12	COMMENT CHOISIR
14	PORTES AUTOBLOQUANTES
20	PORTES EN ALUMINIUM EXTRUDÉ
28	PORTES EN ALUMINIUM PROFILÉ
30	COFFRES POUR PORTES
32	SYSTÈME EXTREME
34	IMPRESSION PAR SUBLIMATION ANTIGRAFFITI
37	FICHES TECHNIQUES
64	GLOSSAIRE DES SYSTÈMES



V-77

01 | SEGURIDAD

Las ventanas y las puertas son dos de los puntos más débiles en el conjunto de la vivienda, frente a la intrusión de personas no deseadas en su interior.

La solución de Persax es una amplia gama de puertas enrollables, destacando especialmente los sistemas autoblocantes, que aportan una seguridad adicional antirrobo.

EN SECURITY

Windows and doors are the two weakest points against the access of unwanted people inside the home.

PERSAX solution has a wide range of rolling shutter doors, particularly blocking systems that provide additional security against robbery.

FR SÉCURITÉ

Les fenêtres et les portes sont deux des points les plus vulnérables du logement, à protéger contre l'entrée de personnes non désirées.

La solution de PERSAX réside dans une large gamme de portes enroulables, en particulier les systèmes autobloquants, qui apportent un plus de sécurité contre le vol.

02 | PRACTICIDAD

La seguridad no está reñida con la practicidad. Es por ello que las puertas de Persax disponen de diferentes sistemas de accionamiento.

Además, combinamos esos sistemas de accionamiento con los últimos avances en seguridad para evitar accidentes. Todo ello acorde con la estricta normativa CE de seguridad.

EN PRACTICALITY

Security is not incompatible with practicality. PERSAX roller shutter doors have different operating systems.

Our roller shutter doors also have the latest security features to prevent accidents. All our products meet the strict EC safety regulations.

FR COMMODITÉ

La sécurité n'est pas incompatible avec le caractère pratique. C'est pourquoi les portes de PERSAX offrent différents systèmes d'actionnement.

De plus, nos portes sont équipées des dernières nouveautés en matière de sécurité, pour éviter des accidents. Elles sont conformes à la très stricte réglementation CE en matière de sécurité.

03 | ESTÉTICA

Una de nuestras exigencias, además de la calidad, son los acabados de nuestros productos y la adaptación a la estética de cada proyecto arquitectónico.

Disponemos de una amplia gama de colores y acabados, lo que permite la personalización del producto, convirtiendo a cada modelo en único y exclusivo.

EN AESTHETICS

Apart from quality, the finishing of our products and the aesthetic appearance of every architectural project are one of our major requirements.

We have a wide range of colors and finishing, that allow customization of our products, making each model unique and exclusive.

FR ESTHÉTIQUE

Outre la qualité, nous apportons une attention toute particulière à l'esthétique de nos produits, afin qu'ils puissent s'adapter à tout type d'architecture.

Nous disposons d'une large gamme de couleurs et de finitions, qui nous permettent de personnaliser le produit afin d'en faire un modèle unique et exclusif.

PARTES DE UNA PUERTA

PARTS OF A ROLLER DOOR
COMPOSANTS D'UNE PORTE ENROULABLE

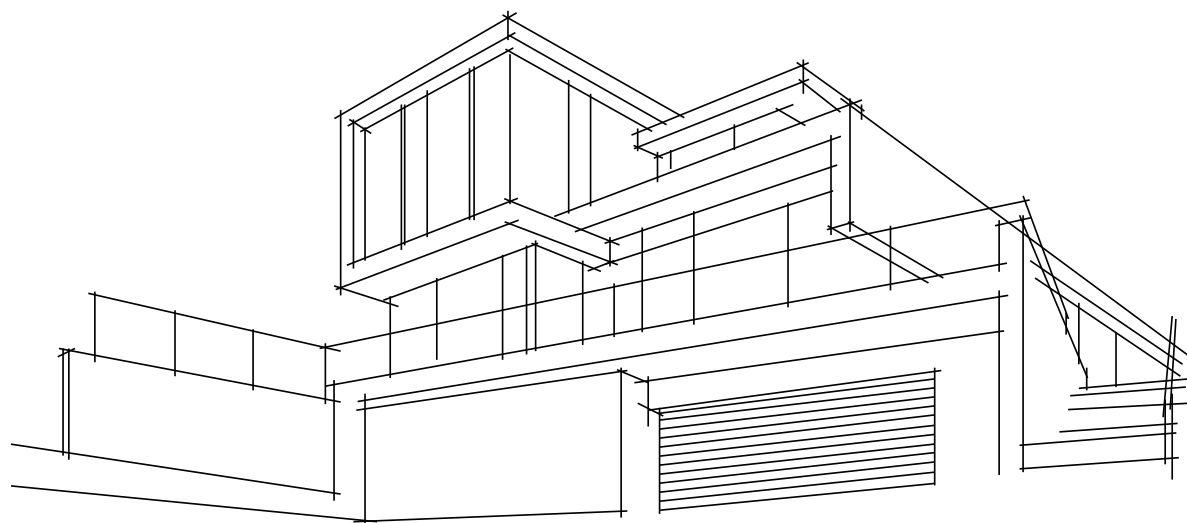

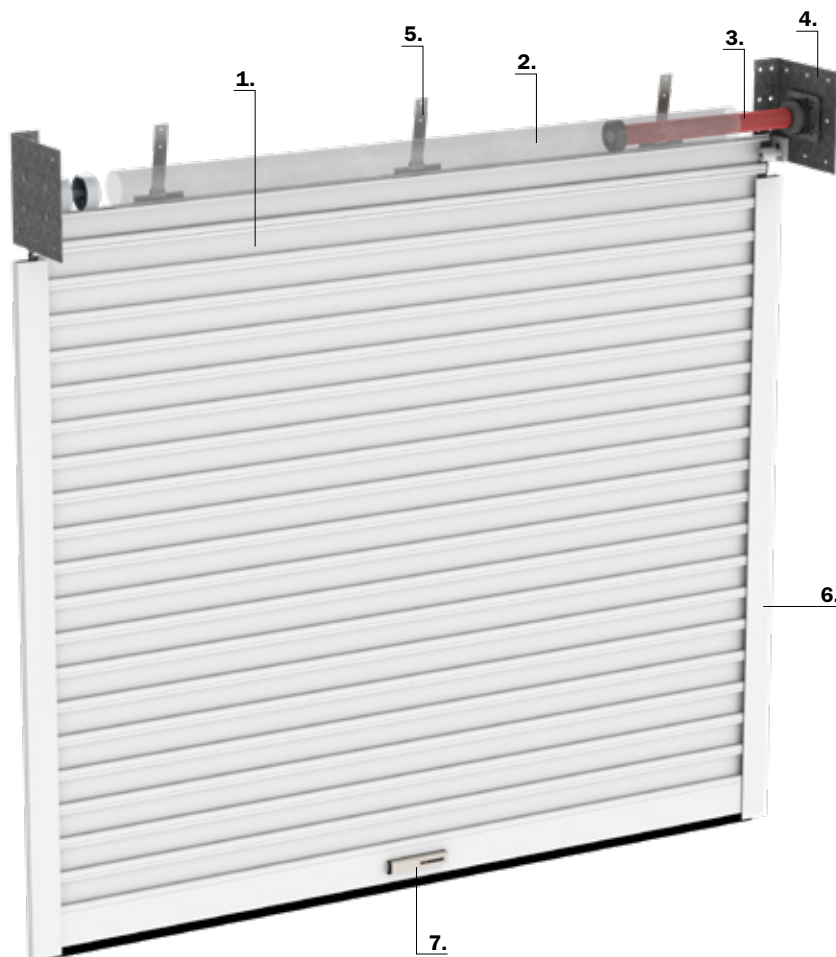

1 PAÑO / CURTAIN / TABLIER

Conjunto de lamas que forman la parte principal de la puerta.
Set of slats that constitute the main part of the roller shutter door.
Ensemble de lames qui composent la partie principale de la porte.

2 EJE / SHAFT / AXE

Elemento sobre el que se enrolla el paño y que sirve como transmisor del movimiento del motor.
The element around which the curtain is rolled, which serves as a transmitter for the movement of the motor.
Élément autour duquel s'enroule le tablier et qui sert au moteur de transmission du mouvement.

3 MOTOR / MOTEUR

Accionamiento automático de la puerta enrollable. Dependiendo de las necesidades, se escoge motor tubular o centro eje.
Automatic activation of the roller shutter door. Depending on needs, a tubular motor or a central motor can be chosen.
Actionnement automatique de la porte enrollable. En fonction des besoins, on choisira un moteur tubulaire ou centre axe.

4 SOPORTES LATERALES / SUPPORTS

Sistema de sujeción de la puerta. Disponibles en aluminio y hierro, según necesidades.
System where the roller shutter door is hold. Available in aluminum and iron, depending on the needs.
Système de fixation de la portes. Disponibles en aluminium et fer, selon les besoins.

5 TIRANTES / SPRINGS / ATTACHES

El elemento que une el paño con el eje y que permite que este enrolle sobre el mismo.
The element that links the curtain with the shaft and enables it to roll up.
L'élément qui relie l'axe au tablier et qui permet à celui-ci de s'enrouler autour de l'axe.

6 GUÍAS / GUIDES / COULISSES

Elementos imprescindibles para el correcto funcionamiento del paño.
Essential elements for the correct operation of the curtain.
Éléments indispensables pour le fonctionnement correct du tablier.

7 SEGURIDAD / SAFETY / BARRE PALPEUSE

Sistema de detección de obstáculos, que funciona por vibración. El sistema de seguridad instalado en el remate, hará que la puerta se detenga cuando un cuerpo o persona contacte tanto en su movimiento de subida como de bajada.
System for the detection of obstacles, that operates by vibration. The safety system installed in the end slat will stop from going up or down the roller shutter door when it touches something or someone.
Système de détection d'obstacles qui fonctionne par vibration. Le système de sécurité installé sur la lame finale entraînera l'arrêt de la porte si un objet ou une personne entre en contact avec celle-ci, aussi bien dans la descente que dans la montée.

TIPOS DE INSTALACIÓN

Las puertas enrollables Persax se adaptan a cualquier necesidad, ya sea para vivienda particular o negocio.

Para ello, disponemos de dos tipos diferentes de instalación: la instalación en obra y la instalación con cajón.

EN TYPES OF INSTALLATION

PERSAX roller shutter doors satisfy any need, whether for a private home or a business.

We have two different types of installation: on-site or with a box.

FR TYPES D'INSTALLATION

Les portes enroulables PERSAX s'adaptent à tous les besoins, autant pour les logements que pour les commerces.

Nous disposons dans ce but de deux différents types d'installation: l'installation en menuiserie et l'installation avec coffre.

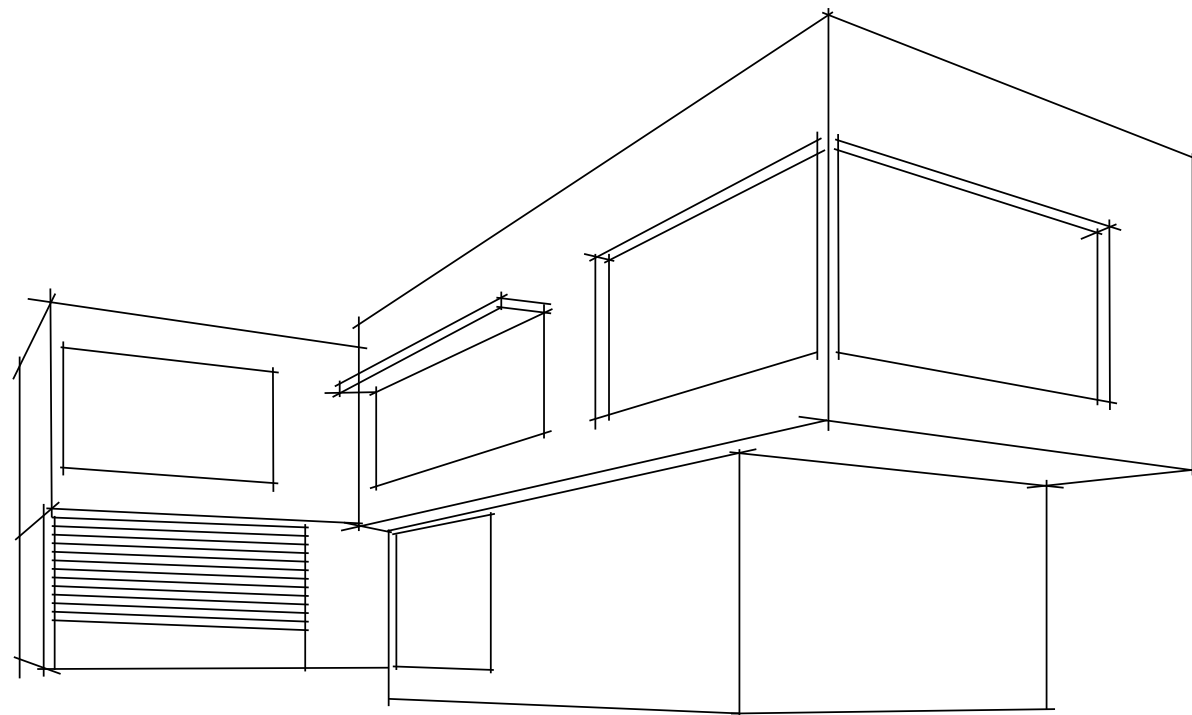



INSTALACIÓN EN OBRA

La opción más tradicional de montar una puerta enrollable. Tiene mayor capacidad de enrollamiento por lo que podemos conseguir mayor altura. Aconsejado en situaciones de falso techo (escayola).

EN ON-SITE INSTALLATION

This is the most traditional way to install a roller shutter door. It has a higher rolling capacity, so it can achieve greater height. Recommended in double ceiling situations (plaster).

FR INSTALLATION EN MENUISERIE

L'option la plus traditionnelle pour le montage d'une porte enroulable. Elle offre une plus grande capacité d'enroulement et permet donc une plus grande hauteur. Recommandée en cas de double toit (plâtre).



INSTALACIÓN CON CAJÓN

La instalación de una puerta enrollable con cajón proporciona una reducción importante del impacto visual, así como menor ruido al accionar la puerta. También ofrece una mayor protección frente a la suciedad (cuando se encuentra recogido).

EN INSTALLATION WITH A BOX

The installation of a roller shutter door with a box provides a significant reduction of visual impact, as well as less noise when the roller door is operating. It also offers higher protection against dirt (when the roller shutter is up).

FR INSTALLATION AVEC COFFRE

L'installation d'une porte enroulable avec coffre apporte une importante réduction de l'impact visuel et du niveau de bruit lors de l'actionnement de la porte. Elle offre également une meilleure protection contre la saleté (lorsqu'elle est enroulée).

FORMAS DE MEDICIÓN

Medir una puerta es sencillo si se conocen una serie de directrices básicas para hacerlo.

A continuación les mostramos una guía para ir sobre seguro a la hora de realizar la toma de medidas.

EN WAYS OF MEASUREMENT

Measuring a roller shutter door is easy if you know a series of basic instructions for doing it.

We provide a guide below to help you to make the measurements.

FR PRISE DE COTES

Il est facile de mesurer une porte si l'on suit une série de directives simples.

Nous vous montrons ici un guide pour ne pas vous tromper lors de la prise de mesures.

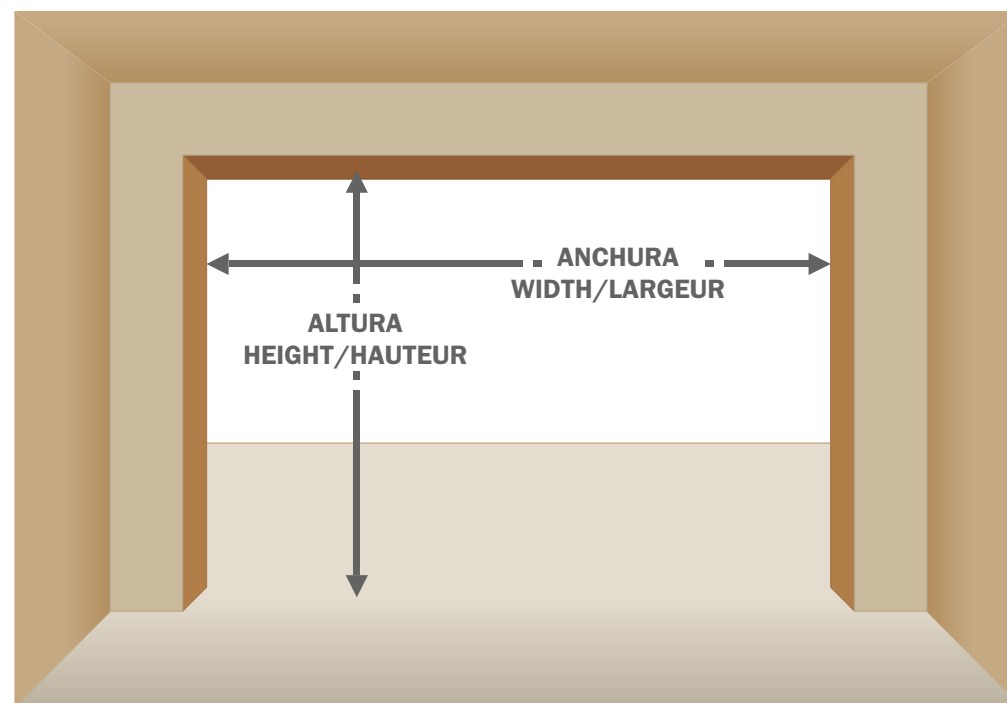

MEDICIÓN HORIZONTAL (anchura de la puerta)

Door width / Largeur de la porte

Guía embutida / In wall guide / Coulisse encastrée

Cuando las guías van dentro (embutidas) de la pared.

When the guides are inside the wall.

Lorsque les coulisses sont encastrées dans le mur.

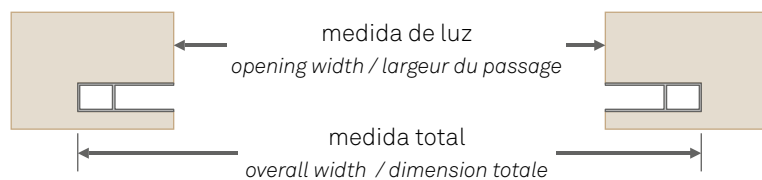

Guía superpuesta / Superimposed guide / Coulisse superposée

Cuando las guías van superpuestas a la pared y quedan en el exterior.

When the guides are superimposed to the wall and remain outside.

Lorsque les coulisses sont superposées sur le mur, du côté extérieur.

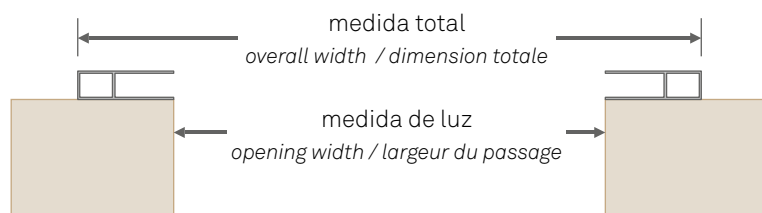

Guía superficie / Surface guide / Coulisse en superficie

Cuando las guías están dentro del hueco de luz (restando tamaño al hueco final).

When the guides are inside the hollow of the opening (subtracting from the size of the final opening).

Lorsque les coulisses sont à l'intérieur de passage (et réduisent la taille de l'espace final).

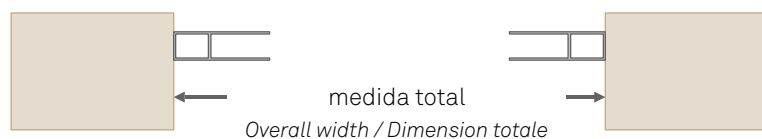

MEDICIÓN VERTICAL (altura de la puerta)

Door height / Hauteur de la porte

1.
medida total
overall width /
dimension totale

2.
medida de luz
opening width / largeur
du passage

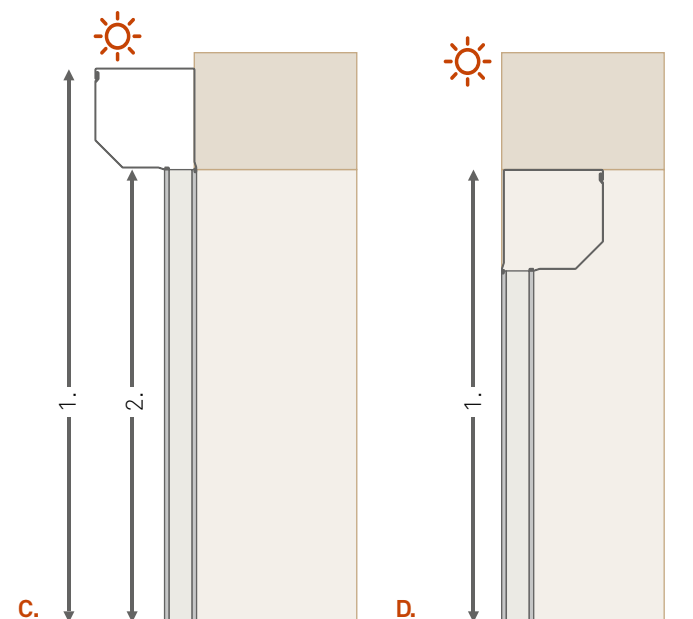
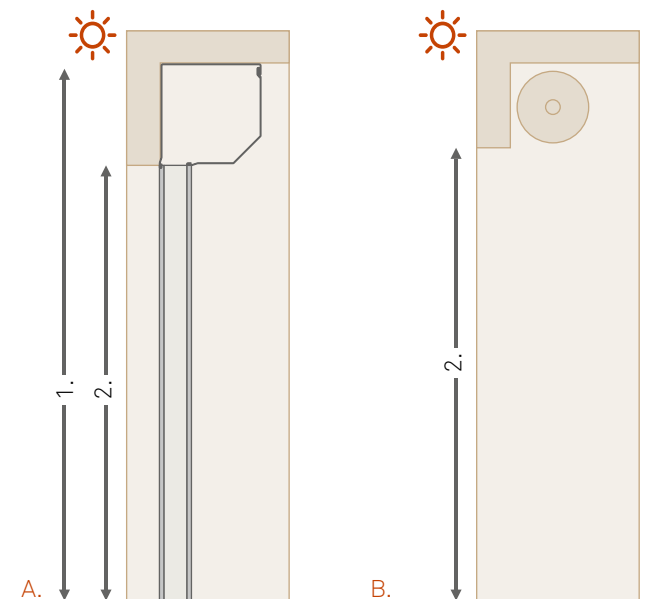

GUÍA DE ELECCIÓN

Cuando pensamos en adquirir una puerta lo primero que nos ha de venir a la mente es “¿cual es la más adecuada para mis necesidades?”.

A continuación le proporcionamos unas indicaciones con el fin de que usted mismo pueda elegir la opción que mas le convenga.

EN

HOW TO CHOOSE

When you think about getting a roller shutter door, the first consideration should be, “which one is this the most suitable for my needs?”

FR

Below, we provide you a few tips that will help you to select the best option, depending of your needs.

COMMENT CHOISIR

Lorsque l'on a l'intention d'acheter une porte enroulable, on doit commencer par se demander: “Quelle est la plus adaptée à mes besoins?”.

Nous vous apportons ici quelques indications pour vous aider à appréhender l'option qui vous conviendra le mieux.

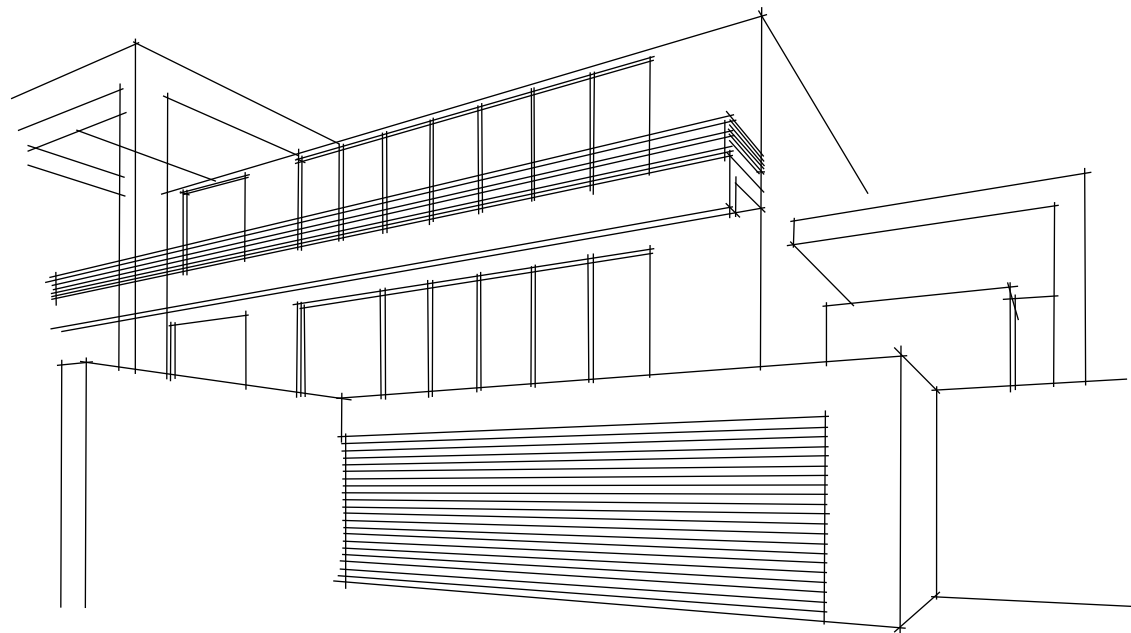

¿CÓMO ELEGIR UNA PUERTA?

HOW TO CHOOSE A DOOR? / COMMENT CHOISIR UNE PORTE?

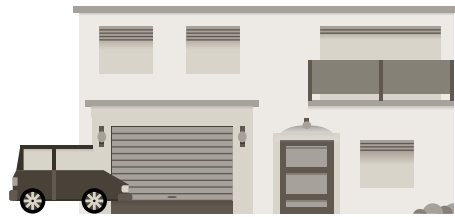

Vivienda particular
Private home / Logement particulier

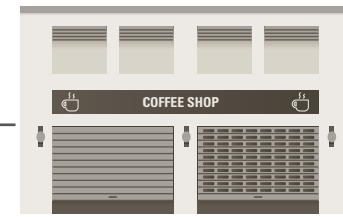

Local comercial*
Commercial site / Local commercial

¿Dónde va colocada?
Where will it go? / Où va-t-elle être installée?

¿Dispone de Entrada Alternativa?
Is there an alternative entrance? / Y a-t-il une autre entrée?

Si / Yes / Oui

No / Non



Tubular
Tubulaire



Centro Eje
Central Shaft / Centre Axe
(muelle y poleas) / (spring and pulleys) / (ressort et poulies)



- SEGUR EC-60
- V-77 MONO PARED
- V-77 PF
- V-80 MONO / DOBLE PARED
- ECOSEGUR - 100
- V-100
- VS-150 BLOCK-60
- VS-300 BLOCK-95
- VS-350 BLOCK-110

Sistemas
Systems/ Systèmes

- SEGUR EC-60
- V-77 MONOPARED
- V-77 PF
- V-80 MONO / DOBLE PARED
- ECOSEGUR - 100
- V-100

Sistemas
Systems/ Systèmes

Opciones adicionales
Additional options / Options supplémentaires

Cajón / Box / Coffre

Soportes / Brackets / Support

- Al. Perfilado 45° / Profiled / Profilé
- Al. Extrusión EXBOX / Extruded / Extrudé
- PVC Max

- Soporte Cajón / Box Bracket / Support Coffre
- Soporte Escuadra / Square Bracket / Support Équerre

PUERTAS AUTOBLOCANTES

El sistema de puerta enrollable VS-Block es la solución perfecta cuando se requiere un alto nivel de seguridad, como puede ser en las joyerías, entidades bancarias, viviendas en planta baja, etc.

Proporciona un alto nivel de seguridad gracias a su sistema de varillas intermedias que ejercen presión sobre las guías. Esta acción dificulta el levantamiento vertical de la puerta desde el exterior y por tanto el acceso al interior de la vivienda o comercio.

Modelos **VS-150 BLOCK-60**, **VS-300 BLOCK-95** y **VS-350 BLOCK110**.

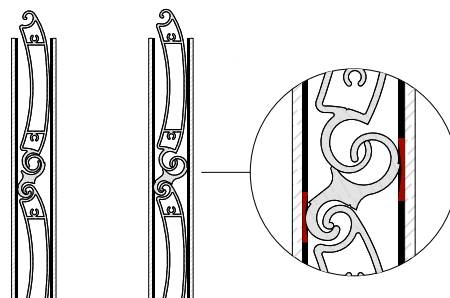

- Lama de extrusion de doble pared con perfil intermedio autoblocante.
- Disponibles también en versiones troquelada y troquelada con metacrilato para dar más luminosidad al interior.
- El modelo VS-350 Block 110 es uno de los pocos modelos del mercado que además de ser autoblocante, se puede microperforar.



VS-300 BLOCK-95

SELF-BLOCKING ROLLER DOORS

EN *The VS-Block roller shutter door is the perfect solution if you need high security such as in jewelry shops, banks, ground floor homes, etc.*

It provides a high level of security thanks to the pressure that the intermediate slat system make on the guides.

This action prevents to lift the roller shutter door vertically from the outside and therefore impedes access inside the home or sites.

Models VS-150 Block-60, VS-300 Block-95 and VS-350 Block-110

- **Extruded double-skin slat with self-blocking intermediate profile.**
- **Also available in punched without or with methacrylate slats to give more bright.**
- **The VS-350 Block 110 model is one of the few models of the market that can be perforated, in addition to being self-blocking.**

PORTES AUTOBLOQUANTES

FR *Le système de porte enroulable VS-Block est la solution parfaite si l'on recherche un niveau de sécurité élevé, par exemple dans les bijouteries, les établissements bancaires, les logements au rez-de-chaussée, etc.*

Il apporte un niveau élevé de sécurité grâce à son système de lames intermédiaires qui font pression sur les coulisses. Cette action rend très difficile la montée verticale de la porte depuis l'extérieur, et donc l'accès à l'intérieur du logement ou du local commercial.

Modèles VS-150 Block-60, VS-300 Block-95 et VS-350 Block-110

- **Modèles avec lames extrudées à double paroi et lames intermédiaires autobloquantes.**
- **Également disponibles en versions ajourée, ajourée avec méthacrylate (hublot) pour donner plus de luminosité à l'intérieur.**
- **Le modèle VS-350 Block 110 est l'un des rare modèle du marché qui, en plus d'être autobloquant, peut être microperforé.**



VS-300 BLOCK-95

MODELOS AUTOBLOCANTES

SELF-BLOCKING MODELS / MODÈLES AUTOBLOQUANTS

VS-150 BLOCK 60 MONO/DOBLE PARED

Single - Double-Skin / Mono - Double-Paroi

Un estándar en seguridad. Recomendada para viviendas, garajes y locales comerciales que necesiten seguridad. También dispone de versión "monopared" que se puede troquelar y colocar metacrilato.

Recommended for homes, garages and commercial sites that need security. There is also a "single-skin" version that can be punched and covered with methacrylate.

Recommandée pour les logements, garages et locaux commerciaux ayant besoin de sécurité. Existe aussi en version «monoparoi», qui permet l'ajourée et la pose de méthacrylate (hublot).

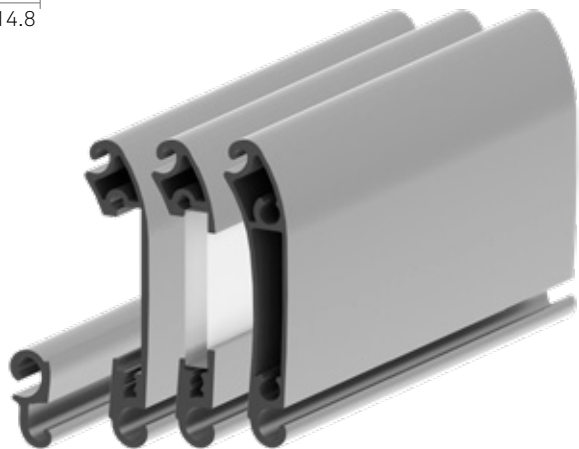
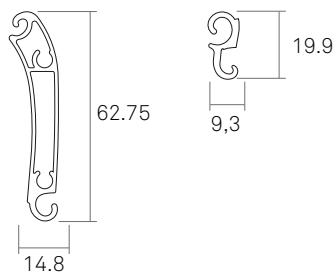

VS-300 BLOCK-95 MONO/DOBLE PARED

Single - Double-Skin / Mono - Double-Paroi

La lama reina en seguridad. Está especialmente recomendada para comercios que requieran un extra de seguridad, como por ejemplo farmacias o joyerías. También dispone de versión "monopared" que se puede troquelar y colocar metacrilato.

Especially recommended for commercial sites that require extra security such as, for example, pharmacies or jewelry shops. There is also a "single-skin" version that can be punched and covered with methacrylate.

Spécialement recommandée pour les commerces exigeant une sécurité maximale, par exemple les pharmacies ou les bijouteries. Existe aussi en version «monoparoi», permettant l'ajourée et la pose de méthacrylate (hublot).

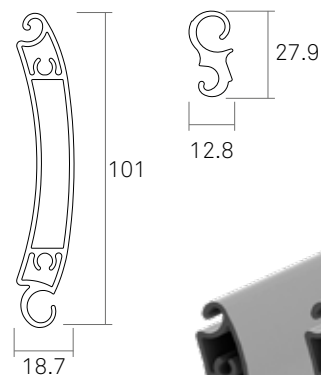

VS-350 BLOCK 110 MONOPARED

Single - Skin / Monoparoi

NUEVO / NEW / NOUVEAU

La lama VS-350 Block 110 tiene las ventajas de las lamas autoblocante, siendo óptima donde se requiera una alta seguridad. Es además ideal para grandes superficies que necesiten un mayor paso de luz. Esta lama tiene la ventaja de ser plana, dando un toque estético muy atractivo, permitiendo troquelarla y microperforarla.

The VS-350 Block 110 slat has the advantages of the selfblocking slats, being optimal where a high security is required. Moreover, it is ideal for large areas that need light. This slat has also the advantage of being flat, giving an aesthetic appeal, allowing it to be punched and perforated.

La lame VS-350 Block 110 a les avantages des lames autobloquantes, étant optimale lorsque une sécurité élevée est nécessaire. Elle est de plus idéale pour les grandes superficies qui nécessitent le passage de la lumière. Cette lame a l'avantage d'être plate, donnant une touche esthétique très attrayante, permettant l'option ajourée et microperforée.

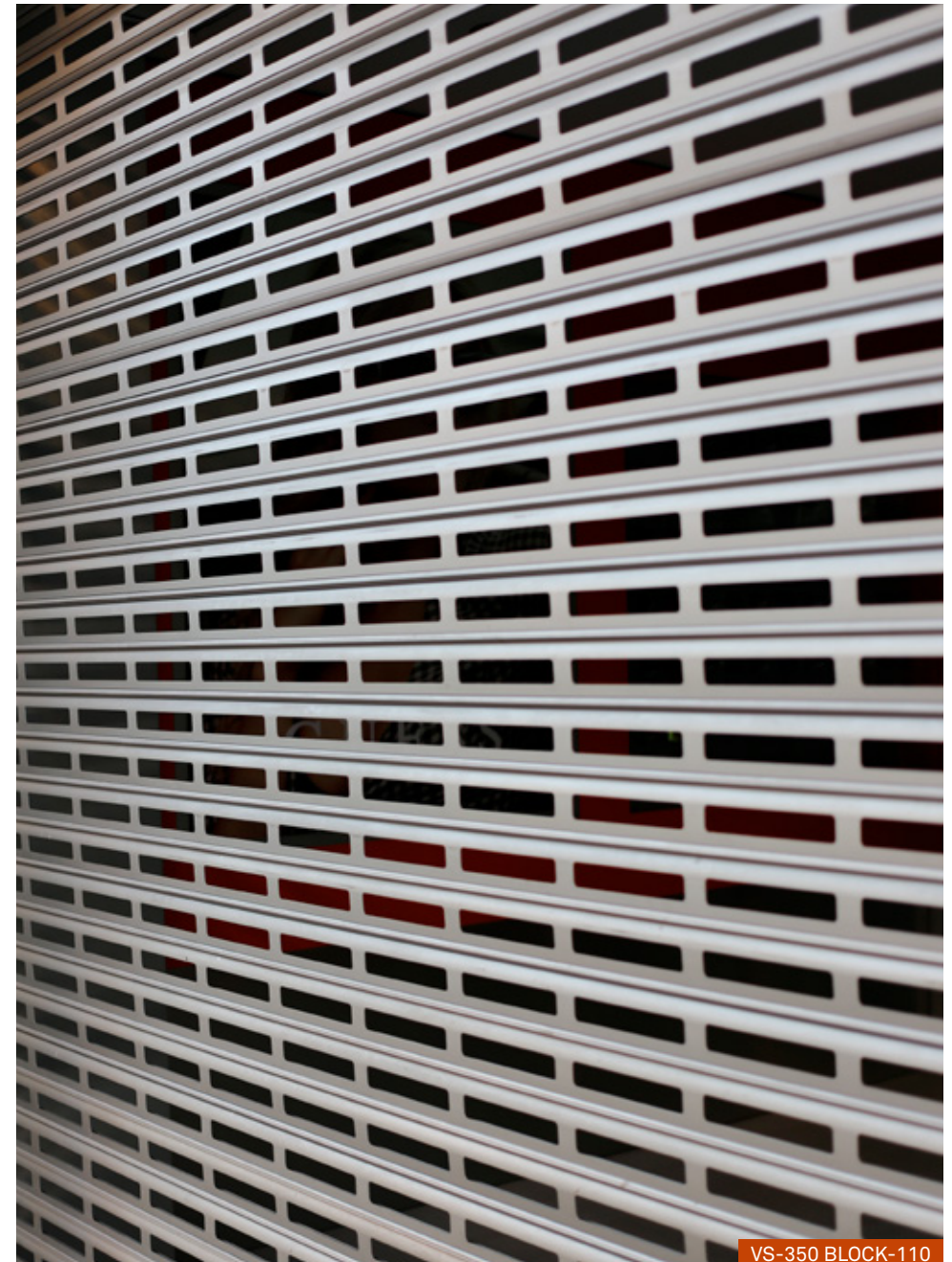
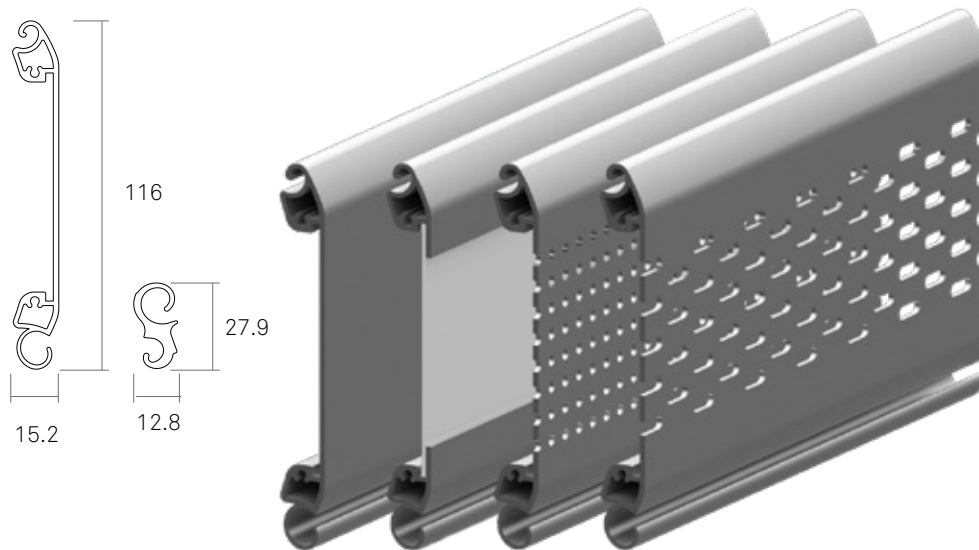

VS-350 BLOCK-110

OPTICA VISIO



VS-300 BLOCK-95



PUERTAS ALUMINIO EXTRUSIÓN

Su versión microperforada está recomendada cuando se busca ventilación interior.

La versión troquelada se dirige especialmente para escaparates de comercios que deseen dar una buena visibilidad del interior garantizando la seguridad del local.

Las puertas enrollables de aluminio de extrusión de Persax se adaptan a cualquier necesidad, ofreciendo tamaños que van desde los 60 mm de alto por lama hasta los 100 mm, lo que convierte a esta gama en la más versátil.

Modelos Segur **EC-60, V-77, V-80, V-100** y **ECOSEGUR -100**

- **Aconsejadas para comercios, garajes y viviendas.**
- **Posibilidad de microperforado, troquelado y troquelado con metacrilato.**



EXTRUDED ALUMINIUM DOORS

EN *The perforated version is recommended when you are looking for interior ventilation.*

The punched version is specially designed for shop windows to give good visibility to the inside while ensuring the security of the commercial site.

PERSAX extruded aluminum roller shutter doors can adapt to every need, with sizes from 60 mm height per slat to 100 mm, making it the most versatile range.

Models Segur EC-60, V-77, V-80, V-100 and ECOSEGUR - 100

■ Recommended for commercial sites, garages and homes.

■ Options include perforated, punched and punched with methacrylate.

PORTES EN ALUMINIUM EXTRUDÉ

FR *Sa version microperforée est recommandée si l'on recherche une ventilation intérieure.*

La version ajourée s'adresse particulièrement aux vitrines des locaux commerciaux qui souhaitent offrir une bonne visibilité à l'intérieur tout en garantissant leur sécurité.

Les portes enroulables en aluminium extrudé de PERSAX s'adaptent à tous les besoins avec des tailles allant de 60 à 100 mm de hauteur par lame, ce qui en fait la gamme la plus diversifiée.

Modèles Segur EC-60, V-77, V-80, V-100 et ECOSEGUR - 100

■ Conseillées pour les commerces, garages et logements.

■ Possibilité de microperforation, ajourée et ajourée avec méthacrylate (hublot).



V-77

MODELOS EXTRUSIÓN

EXTRUDED MODELS / MODÈLES EXTRUDÉS

SEGUR EC-60 DOBLE PARED

Double-Skin / Double-Paroi

Lama de extrusión de doble pared muy utilizada en garajes y viviendas. El diseño de esta lama, nos permite un óptimo enrollamiento.

Extruded double-skin slat, very often used in garages and homes. The design of this slat enables optimum rolling.

Lame extrudée à double paroi, très utilisée dans les garages et les logements. La conception de cette lame permet un enroulement optimal.

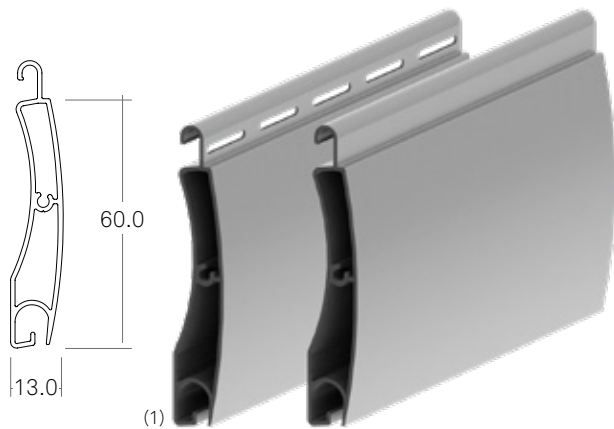

(1) Persax no garantiza la oscuridad total cuando la persiana esta bajada.

Persax does not guarantee the complete darkness when the shutter is lowered.

Persax ne garantit pas l'obscurité totale lorsque le volet roulant est fermé.

V-77 MONOPARED

Single-Skin / Monoparoi

Un clásico dentro del catálogo de Persax. Lama indicada principalmente para locales comerciales. Al ser una lama "monopared" se puede troquelar y permite la combinación con nuestra PF-77

A PERSAX catalogue classic slat mainly suitable for commercial sites. This single-skin slat can be punched and it can be combined with the PF-77 model.

Un classique du catalogue Persax. Principalement indiquée pour les locaux commerciaux, c'est une lame monoparoi. Elle peut donc être ajourée et combinée avec le modèle PF-77.

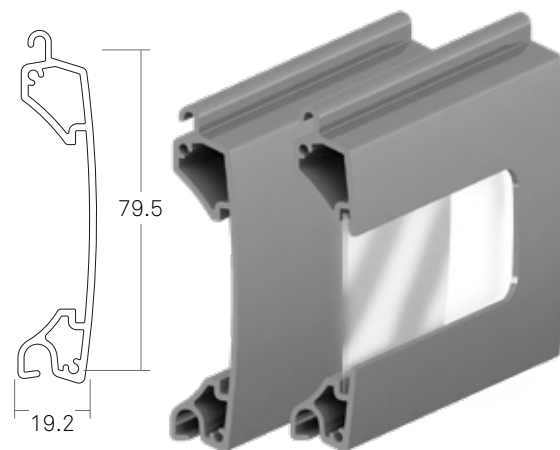

V-80 MONO/DOBLE PARED

Single - Double-Skin / Mono - Double-Paroi

Lama de aluminio recta de carácter formal y atractivo. Su combinación con la versión "monopared" nos permite troquelarla y troquelarla con metacrilato para dar mayor visibilidad al interior.

Straight aluminum slat with a formal and attractive appearance. When combined with the single-skin version, it can be punched and covered with methacrylate to give higher visibility to the interior.

Lame droite en aluminium, formelle et attractive. La combiner avec la version monoparoi permet l'aspect ajourée et la pose de méthacrylate pour une plus grande visibilité sur l'intérieur.

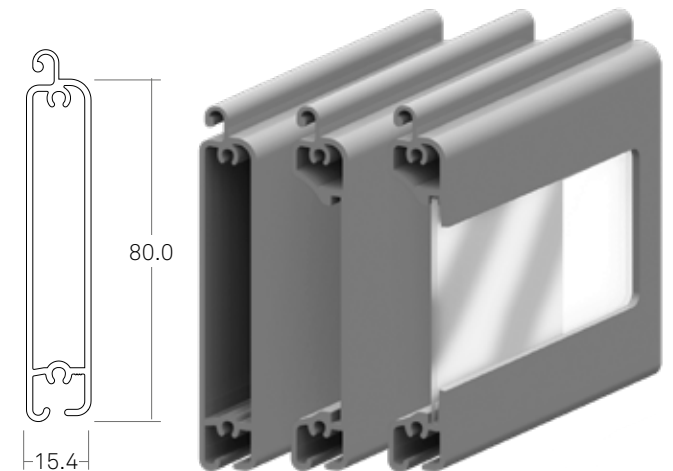

Impresión por sublimación
Sublimation printing
Impression par sublimation



V-100 MONOPARED

Single-Skin / Monoparoi

Con este modelo se pueden conseguir grandes dimensiones. Una lama recta y sobria que nos permite los siguientes modelos: ciega, microperforada, troquelada y troquelada con metacrilato.

This model is suitable for large dimensions. Straight and discrete slat that comes in the following versions: blind, perforated, punched and punched with methacrylate.

Ce modèle permet d'obtenir de grandes dimensions. Une lame droite et sobre qui nous permet les modèles suivants: sans ajourée, microperforée, ajourée et ajourée avec méthacrylate (hublot).

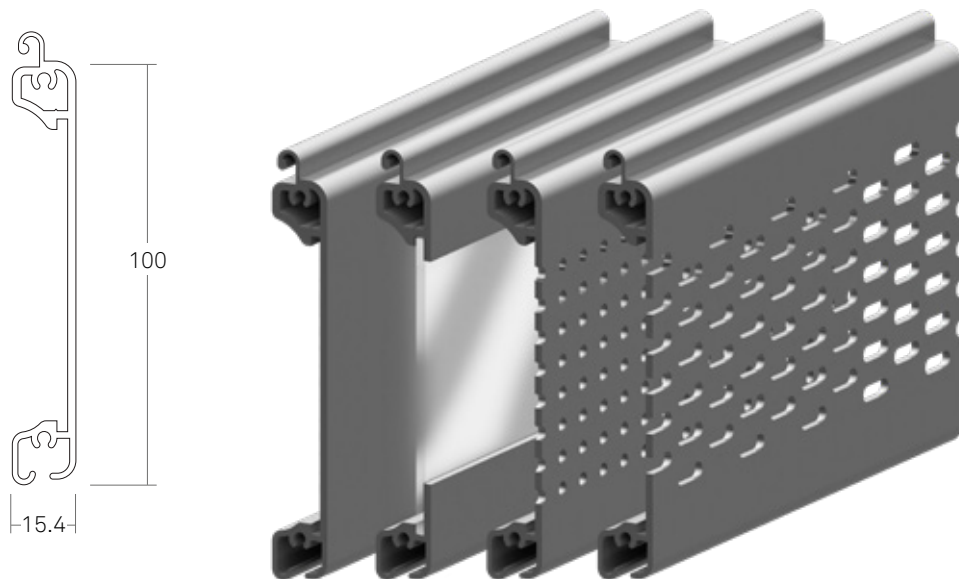

Impresión por sublimación
Sublimation printing
Impression par sublimation



ECOSEGUR - 100

Single-Skin / Monoparoi

NUEVO / NEW / NOUVEAU

Modelo de lama más utilizada en locales comerciales por sus prestaciones. Es ideal para sustituir las antiguas persianas galvanizadas, sin hacer obra. Disponible en versión microperforada, troquelada con metacrilato y ciega.

This slat model is most commonly used in commercial premises due to its performance. It is ideal for replacing the old galvanised blinds, without having to do any building work. Available in micro-perforated, die-cut with methacrylate and blind versions.

Ce modèle de lamelles est le plus utilisé dans les locaux commerciaux en raison de ses performances. Il est idéal pour remplacer les anciens stores galvanisés, sans travaux. Disponible en version micro-perforée, découpée avec du méthacrylate et aveugle.

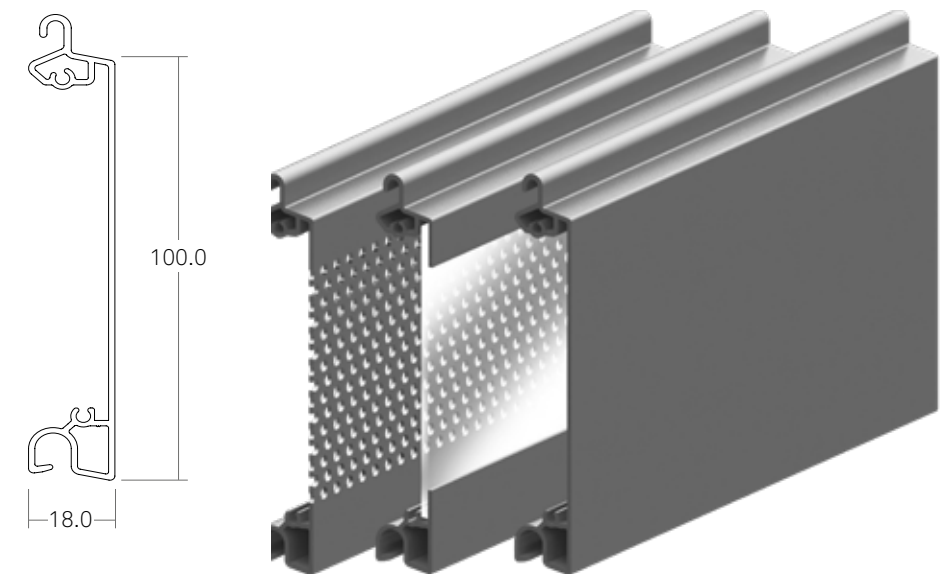

Impresión por sublimación
Sublimation printing
Impression par sublimation







V-100



Segur EC-60



V-80



V-100



V-77

PUERTAS ALUMINIO PERFILADO

Porque no siempre la prioridad es la seguridad, Persax dispone de su modelo de lama V-77 PF.

Fabricada en aluminio perfilado y con poliuretano de alta densidad, la lama V-77 PF ofrece para su negocio o garaje, un aislamiento acústico y térmico para su interior. Todo ello con un precio ajustado y adaptado a los clientes que necesitan un cerramiento básico.

Este modelo puede ser combinado con la V-77 MONOPARED.

■ Aporta aislamiento acústico y térmico

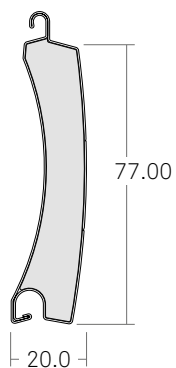



FOAM FILLED ALUMINIUM DOORS

EN Security is not always the priority, therefore PERSAX also offers the slat model V-77 PF.

Made in foam filled aluminium and high density polyurethane, the V-77 PF slat offers acoustic and thermal insulation for the interior of your business or garage. This comes in an affordable price, suitable for customers who need a basic roller shutter door.

Allows to be combined with V-77 Single-Skin model.

■ Provides acoustic and thermal insulation

PORTES ALUMINIUM PROFILÉ

FR Parce que la priorité n'est pas toujours la sécurité, PERSAX dispose de son modèle de lame V-77PF.

Fabriquée en aluminium profilé et en polyuréthane haute densité, la lame V-77PF apporte une protection acoustique et thermique à votre commerce ou votre garage. Et ce avec des prix ajustés et adaptés aux clients qui recherchent une porte simple.

Permet d'être combinée avec le modèle V-77 Monoparoi.

■ Apporte isolation acoustique et thermique

CAJONES PARA PUERTAS

Los cajones para las puertas enrollables dotan al conjunto de una mayor protección frente a la suciedad. Además, reducen el impacto acústico de la puerta durante las maniobras de apertura y cierre.

Disponemos de tres modelos que se adaptan a cualquier necesidad.

EN BOXES FOR DOORS

Boxes for roller shutter doors provide the assembly with higher protection against dirt. They also reduce the acoustic impact of the door during opening and closing of the roller shutter door.

We have three models that meet any need.

FR COFFRES POUR PORTES

Les coffres pour les portes enroulables apportent à l'ensemble une plus grande protection contre la saleté. De plus, ils réduisent l'impact acoustique de la porte durant les manoeuvres d'ouverture et de porte.

Nous disposons de trois modèles qui s'adaptent à tous les besoins.



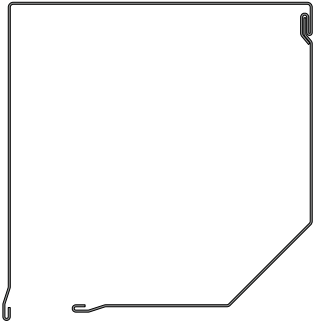

CAJÓN DE ALUMINIO PERFILADO 45°
45° Aluminium Box / Coffre Alu. Profilé 45°

Los cajones de aluminio perfilado poseen una amplia gama de tamaños que se adaptan a cualquier necesidad y además disponen de una completa gama de colores con la posibilidad de una integración total con la carpintería consiguiendo con ello una uniformidad en su vivienda.

Aluminium boxes come in a wide range of sizes that meet every need and also in a full range of colors with the option of total integration into the carpentry, thereby achieving uniformity of your home.

Les coffres en aluminium profilé sont disponibles dans une large gamme de tailles s'adaptant à tout type de besoin. De plus, ils disposent d'une gamme complète de couleurs et offrent la possibilité d'une intégration totale à la menuiserie, ce qui apporte une certaine uniformité au logement.

Tamaños / Dimensions
45° 250, 300, 350, 400

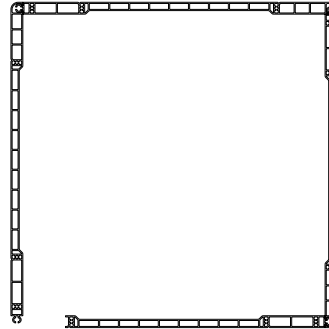

CAJÓN DE PVC MAX
PVC MAX Box / Coffre PVC MAX

El nuevo cajón de PVC MAX está especialmente indicado para viviendas que busquen un aislamiento térmico y acústico alto. Cajón registrable por su parte frontal, especialmente indicado para su instalación sobre carpintería. La posibilidad de polyespan le confiere un mayor aislamiento térmico y acústico.

The new PVC MAX box is specially designed for homes seeking high thermal and acoustic insulation. Box that can be accessible through the front profile, especially suitable for installation on carpentry. The option to include expanded polystyrene gives it higher thermal and acoustic insulation.

Le nouveau coffre PVC MAX est particulièrement indiqué pour les logements qui ont besoin d'une isolation thermique et acoustique élevée. Coffre registrable sur l'avant, particulièrement indiqué pour une installation sur menuiserie. La possibilité du polystyrène lui confère une plus grande isolation thermique et acoustique.

Tamaños / Dimensions
275, 305

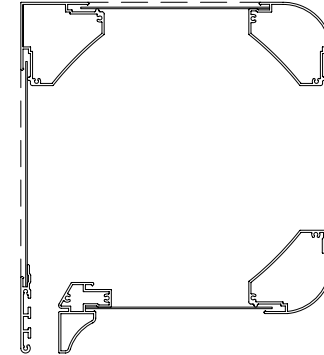

CAJÓN ALUMINIO DE EXTRUSIÓN EXBOX
Extruded Alu. EXBOX / Coffre Alu. Extrudé EXBOX

Cajón resistente, robusto y de gran diseño especialmente indicado para instalaciones exteriores donde el cajón queda visto. Al tener todos los componentes de aluminio de extrusión, permite igualar el color y el tono del lacado entre cajón, guías y paño.

Strong, robust and well-designed box, especially suitable for exterior installation where the box remains visible. Thanks to have all components in extruded aluminium, the colour and coating tone can be equalized between box, guides and shutter.

Coffre résistant, robuste et de grande dimension, spécialement conçu pour des installations extérieures où le coffre est visible. L'ensemble des composants étants en aluminium extrudé, la couleur et la tonalité du laquage peuvent être égalisées entre coffre, coulisses et tablier.

Tamaños / Dimensions
300, 350, 400, 450

SISTEMA EXTREME

Nuestro sistema de seguridad **EXTREME**, está especialmente indicado para zonas donde se requiera un extra de seguridad por el alto índice de robos o con climas extremos, resistiendo a vientos huracanados de más de 300 km/h.

Compatible con lamas VS-150, VS-300, Segur EC-60 y V-100, el sistema Extreme consta de un tapón y guía especial que aportan un extra de resistencia y seguridad a todo el conjunto de la puerta.

- Extrema seguridad, el sistema V-150 y VS-300 además es autoblocante.
- Capaz de soportar vientos de más de **300 km/h** (VS-150 Block-60).
- Reducción del importe a pagar por su factura en el seguro de la vivienda o edificio.

Presión ejercida por el viento o en un intento de robo

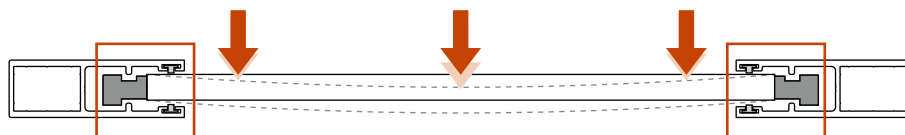

Los tapones, en conjunto con la guía impiden que la lama se salga



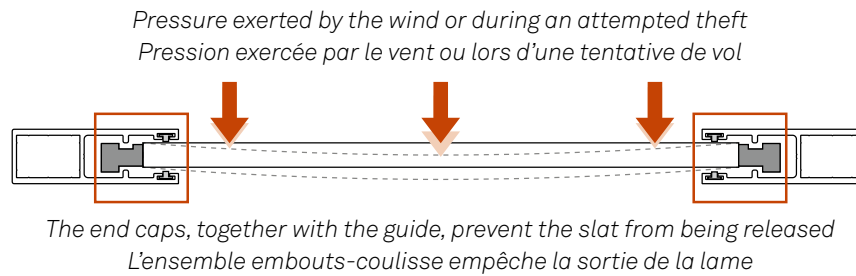

EXTREME SYSTEM

EN Our security system *EXTREME* is especially suitable for areas requiring extra security due to high burglary rates or extreme weather conditions. It can resist hurricane winds of over 300 km/h.

Compatible with VS-150, VS-300, Segur EC-60 and V-100 slats, the *Extreme* system consists of a special end cap and guide that provide extra strength and security to whole roller shutter door system.

■ Extreme security, the VS-150 and VS-300 system is also self-blocking.

■ Able to resist winds of over **300 km/h** (VS-150 Block-60).

■ I also can lower the amount of your home insurance policy.



SYSTÈME EXTRÊME

FR Notre système de sécurité *EXTREME* est spécialement conçu pour les zones où un plus de sécurité est nécessaire en cas de taux de vol élevé ou de climat extrême, puisqu'il résiste à des vents cycloniques de plus de 300 km/h.

Compatible avec les lames V-150 Block-60 et Segur EC-60, le système *Extreme* est équipé de coulisses et d'embouts spéciaux qui renforcent la résistance et la sécurité de l'ensemble de la porte.

■ Sécurité extrême, le système V-150 et VS-300 est aussi autobloquant.

■ Capable de supporter des vents de plus de **300 km/h** (V-150 Block-60).

■ Permet de réduire le montant de votre assurance logement ou bâtiment.

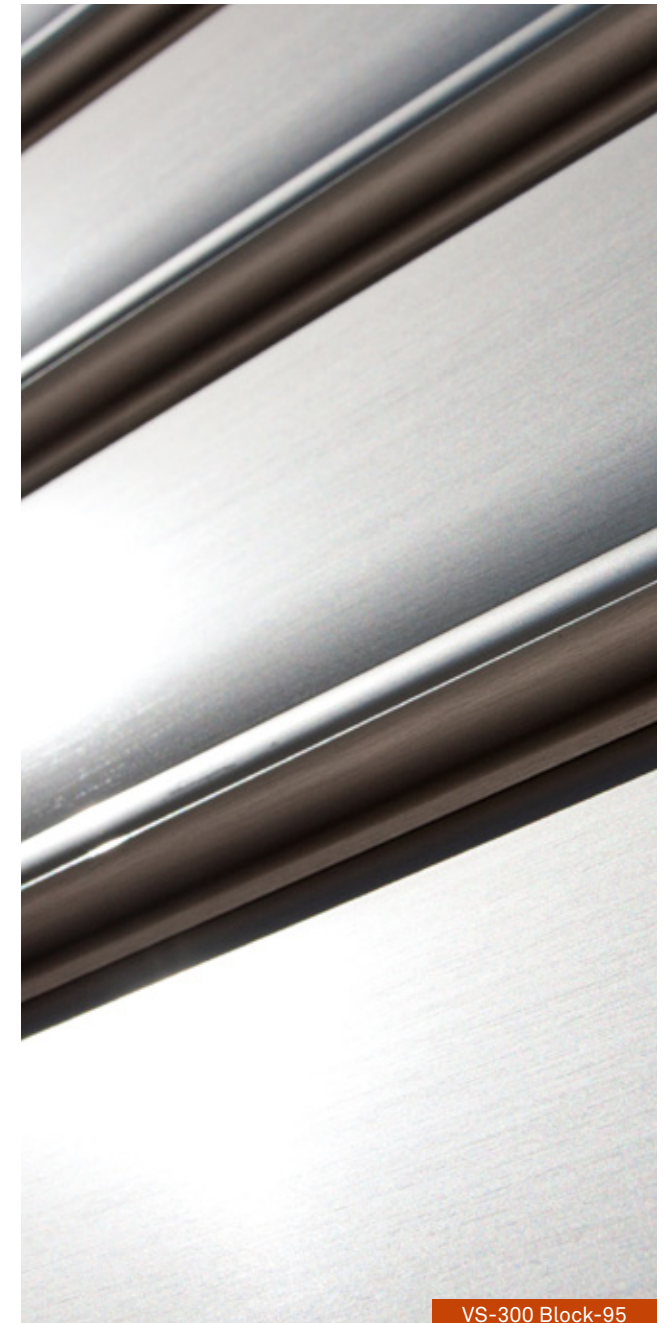

VS-300 Block-95

IMPRESIÓN POR SUBLIMACIÓN ANTIGRAFITI

Hoy en día la imagen de un comercio o un restaurante es algo que se tiene que cuidar especialmente, puesto que es lo que llama la atención del consumidor y lo que le invita a acceder a su interior o no. Pero la buena imagen empieza desde la misma entrada, que es la carta de presentación.

Es por esto que Persax ofrece un servicio de impresión de las puertas para, de ese modo, personalizarlos a la medida del cliente, quedando perfectamente integradas en la estética general.

Además, nuestro acabado ANTIGRAFITI le permitirá tener la puerta libre de cualquier actuación vandálica.

Para su óptimo resultado, le aconsejamos que tome nota de las siguientes recomendaciones:

- En el caso de que se trate de una imagen, lo óptimo es que la imagen se encuentre a tamaño real y con una resolución de 300 puntos por pulgada.
- Para logotipos, el formato óptimo es "vectorial". Para ello son aconsejables los siguientes formatos: ai (Adobe Illustrator) o cdr (Corel Draw).



ANTI-GRAFFITI SUBLIMATION PRINTING

EN Nowadays, the image of a business or a restaurant is something that must be specially considered, this is what first comes to consumers' attention and what invites them to enter or not. A good image starts from the access door, which acts like a first sight.

This is the reason why PERSAX offers a printing service for roller shutter doors so that can be customized for each client, integrating them perfectly into the general aesthetic.

Furthermore, our ANTI-GRAFFITI finish enables keeping the roller shutter doors protected against any vandalism.

For optimum results, please take note of the following recommendations:

- **In the case of an image, this one should be in real size with a resolution of 300 dots per inch.**
- **For logos, the optimum format is "vector". The recommended file formats are: *.ai (Adobe Illustrator) or *.cdr (Corel Draw).**

IMPRESSION PAR SUBLIMATION ANTIGRAFFITI

FR Aujourd'hui, il est particulièrement important de soigner l'image d'un commerce ou d'un restaurant, puisque c'est elle qui attirera le client et l'invitera ou non à y entrer. Mais la bonne image commence dès l'entrée, qui est en quelque sorte la carte de visite.

C'est pourquoi PERSAX offre un service d'impression de portes qui permet une personnalisation sur mesure pour obtenir des portes parfaitement intégrées à l'esthétique générale.

De plus, notre finition ANTIGRAFFITI vous permettra de maintenir votre porte à l'abri des actions de vandalisme.

Pour un résultat optimal, nous conseillons de suivre ces recommandations:

- **S'il s'agit d'une photo, l'idéal est qu'elle soit à taille réelle et à une résolution de 300 points par pouce.**
- **S'il s'agit d'un logo, le format optimal est « vectoriel ». Les formats recommandés sont: ai (Adobe Illustrator) ou cdr (Corel Draw).**



V-10



V-100



V-100



V-100

PERSAX[®]
siente el espacio

FICHAS TÉCNICAS PUERTAS ENROLLABLES

TECHNICAL DATA SHEETS ROLLER SHUTTER DOORS
FICHES TECHNIQUES PORTES ENROULABLES



240002 VS-150 BLOCK60

FICHA DE SISTEMA / SYSTEM DATASHEET / FICHE TECHNIQUE DU SYSTÈME / FICHA DE DADOS DO SISTEMA

313002 LAMA AL VS-150 BLOCK 60- DOBLEPARED / 313060 LAMA AL VS-150 BLOCK 60 - MONOPARED

Datos técnicos

Technical parameters / Paramètres techniques / Dados técnicos

Material Matière	AL. 6063T5
Lamas por metro de altura Necessary slats per height meter / Nombre de lames au mètre Lâminas por metro de altura	13,7
Superficie de cobertura (mm) Surface coverage / Surface de couverture	73
Eje mínimo de enrollamiento Ø (mm) Minimum rolling shaft / Axe minimal d'enroulement / Eixo mínimo de enrolamento	70
Resistencia al viento (Clase) UNE - EN 13241 Wind resistance / Résistance au vent Resistência ao vento	2
Anchura ensayada Tested width / Largeur du tablier testée	4,50 m
Peso m² aprox. Weight per m2 / Poids m ² approximatif	10,4 Kg / m ²
Incremento peso + 30% (Lamas + Varillas unión) para motor Weight increased + 30% (Union slats + slats) for motor Augmentation poids + 30 %	3,12 Kg / m ²



Resistencia al viento según UNE-EN 13241

Wind resistance according to UNE-EN 13241

Résistance au vent conformément à la norme UNE-EN 13241

Clase de Viento

- C1 : 300 Pa ≈ 80 km/h
- C2 : 450 Pa ≈ 98 km/h
- C3 : 700 Pa ≈ 122 km/h
- C4 : 1000 Pa ≈ 145 km/h
- C5 : Mayor a 1000 Pa

Ancho de paño (mm)

Shutter width
Largeur du tablier



4500

Lama

Slats / Lame / Lama

313002 LAMA DOBLEPARED

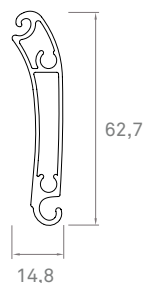

Lama

Slats / Lame / Lama

313060 LAMA MONOPARED

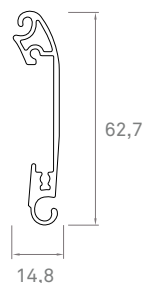

Varilla

Middle slat / Lame intermédiaire

313044 VARILLA UNIÓN



Remate

End slat / Lame finale

313028 REMATE



360004 GOMA REMATE

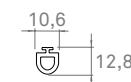

Guía ensayada

Tested guides / Coulisses testées

308209 GUÍA AL GA-95

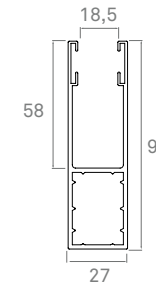

Otras guías compatibles
Other compatible guides
Autres coulisses compatibles

H-76
HC-66

Material Matière	Aluminio 6063T5
Espesor aprox. (mm) Approx. thickness / Épaisseur approx / Grossura nominal	1,2
Peso m. lineal (g) Linear m. weight / Poids m. linéaire / Peso linear	562
Perímetro total (mm) Total perimeter / Périmètre total / Perímetro total	300

Material Matière	Aluminio 6063T5
Espesor aprox. (mm) Approx. thickness / Épaisseur approx / Grossura nominal	1,8
Peso m. lineal (g) Linear m. weight / Poids m. linéaire / Peso linear	546
Perímetro total (mm) Total perimeter / Périmètre total / Perímetro total	242

Material Matière	Aluminio 6063T5
Espesor aprox. (mm) Approx. thickness / Épaisseur approx / Grossura nominal	2,0
Peso m. lineal (g) Linear m. weight / Poids m. linéaire / Peso linear	197
Perímetro total (mm) Total perimeter / Périmètre total / Perímetro total	84

Material Matière	Aluminio 6063T5
Espesor aprox. (mm) Approx. thickness / Épaisseur approx / Grossura nominal	1.2
Peso m. lineal (g) Linear m. weight / Poids m. linéaire / Peso linear	645
Perímetro total (mm) Total perimeter / Périmètre total / Perímetro total	354

Material Matière	Aluminio 6063T5
Espesor aprox. (mm) Approx. thickness / Épaisseur approx / Grossura nominal	2.0
Peso m. lineal (g) Linear m. weight / Poids m. linéaire / Peso linear	1302
Perímetro total (mm) Total perimeter / Périmètre total / Perímetro total	532

■ **Vista explosionada**
Componentes / Composants

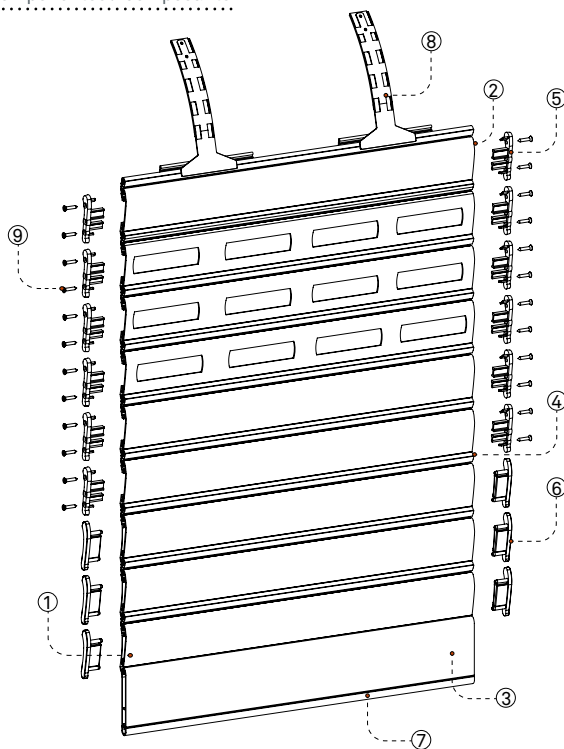

■ **Componentes**
Componentes / Composants

ID	CÓDIGO Code / Código	ARTÍCULOS Articles
1	313002	LAMA DOBLEPARED / Double-skin slat /Lame Double-Paroi
2	313060	LAMA MONOPARED / Single-skin slat /Lame Monoparoi
3	313028	REMATE / End slat / Lame finale
4	313044	VARILLA DE UNIÓN / Middle slat / Lame intermédiaire
5	160281	JGO. TAPÓN LAMA MONOPARED Pair of end caps of single -skin slat / Jeu bouchon lame monoparoi
6	160078	JGO. TAPÓN LAMA DOBLEPARED Pair of end caps of double -skin slat / Jeu bouchon lame double-paroi
7	360004	GOMA REMATE / End slat rubber / Joint lame finale
8	160055	TIRANTE ACERO REVESTIDO / Iron Spring / Attache acier
9	111880	TORNILLO 3,9 x 25 mm / Screw 3,5 x25 (P103925) / Vis 3,5 x 25 (P103925)

■ **Versiones**
Versions

313054 AL VS-150 BLOCK 60

■ **Metacrilato**
Methacrylate / Méthacrylate

311108 VS -150 BLOCK 60 METACRILATO

■ **Tapón compatible**
Compatible side lock / Compatible embout latéra

160281 JGO.TAPÓN AL VS-150 BLOCK 60 MONOPARED

■ **Tapón compatible**
Compatible side lock / Compatible embout latéra

160078 JGO.TAPÓN AL VS-150 BLOCK 60 DOBLEPARED

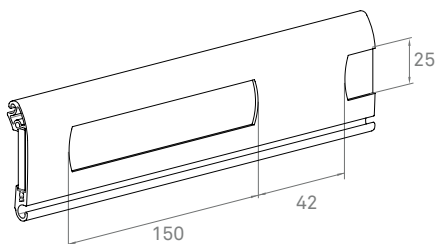

Peso lama troquelada (g/m) Weight / Poids	454
Ventilación (m2/m) Ventilation	0,27

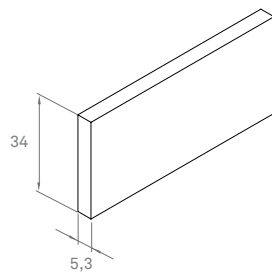
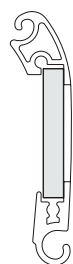

Peso metacrilato (g/m) Weight / Poids	226
--	-----

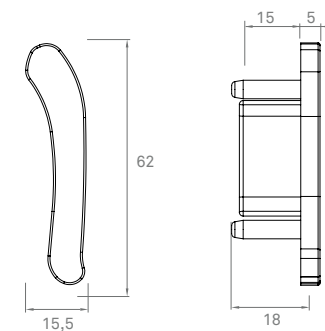
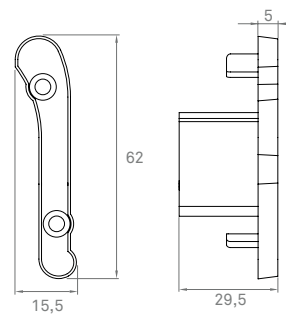

240030 VS-300 BLOCK95

FICHA DE SISTEMA / SYSTEM DATASHEET / FICHE TECHNIQUE DU SYSTÈME / FICHA DE DADOS DO SISTEMA
313192 LAMA AL VS-300 BLOCK 95 / 313058 LAMA AL VS-300 BLOCK 95 MONOPARED

Datos técnicos

Technical parameters / Paramètres techniques / Dados técnicos

Material Matière	AL. 6063T5
Lamas por metro de altura Necessary slats per height meter / Nombre de lames au mètre Lâminas por metro de altura	8,69
Superficie de cobertura (mm) Surface coverage / Surface de couverture	115,07
Eje mínimo de enrollamiento Ø (mm) Minimum rolling shaft / Axe minimal d'enroulement / Eixo mínimo de enrolamento	100
Resistencia al viento (Clase) UNE - EN 13241 Wind resistance / Résistance au vent Resistência ao vento	2
Anchura ensayada Tested width / Largeur du tablier testée	4,50 m
Peso m² aprox. Weight per m2 / Poids m ² approximatif	12,8 Kg / m ²
Incremento peso + 30% (Lamas + Varillas unión) para motor Weight increased + 30% (Union slats + slats) for motor Augmentation poids + 30 %	3,67 Kg / m ²



Resistencia al viento según UNE-EN 13241

Wind resistance according to UNE-EN 13241

Résistance au vent conformément à la norme UNE-EN 13241

Clase de Viento

- C1 : 300 Pa ≈ 80 km/h
- C2 : 450 Pa ≈ 98 km/h
- C3 : 700 Pa ≈ 122 km/h
- C4 : 1000 Pa ≈ 145 km/h
- C5 : Mayor a 1000 Pa

Ancho de paño (mm)

Shutter width
Largeur du tablier



Lama

Slats / Lame / Lama

313192 LAMA DOBLEPARED

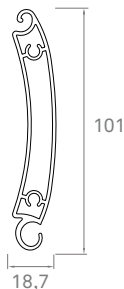

Lama

Slats / Lame / Lama

313058 LAMA MONOPARED

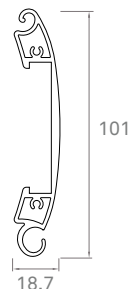

Varilla

Middle slat / Lame intermédiaire

313196 VARILLA UNIÓN



Remate

End slat / Lame finale

313030 REMATE

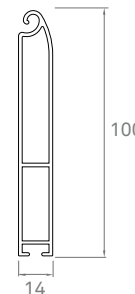

360026 GOMA REMATE

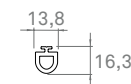

Guía ensayada

Tested guides / Coulisses testées

308205 GUÍA AL GS-130

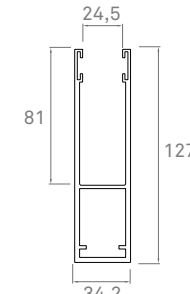

Otras guías compatibles
Other compatible guides
Autres coulisses compatibles

GEM-75
GSO-105
PRM. 105X80

Material Matière	Aluminio 6063T5
Espesor aprox. (mm) Approx. thickness / Épaisseur approx / Grossura nominal	1,5
Peso m. lineal (g) Linear m. weight / Poids m. linéaire / Peso linear	1077
Perímetro total (mm) Total perimeter / Périmètre total / Perímetro total	513

Material Matière	Aluminio 6063T5
Espesor aprox. (mm) Approx. thickness / Épaisseur approx / Grossura nominal	1,8
Peso m. lineal (g) Linear m. weight / Poids m. linéaire / Peso linear	1074
Perímetro total (mm) Total perimeter / Périmètre total / Perímetro total	414

Material Matière	Aluminio 6063T5
Espesor aprox. (mm) Approx. thickness / Épaisseur approx / Grossura nominal	2,0
Peso m. lineal (g) Linear m. weight / Poids m. linéaire / Peso linear	384
Perímetro total (mm) Total perimeter / Périmètre total / Perímetro total	116

Material Matière	Aluminio 6063T5
Espesor aprox. (mm) Approx. thickness / Épaisseur approx / Grossura nominal	1,5
Peso m. lineal (g) Linear m. weight / Poids m. linéaire / Peso linear	1007
Perímetro total (mm) Total perimeter / Périmètre total / Perímetro total	487

Material Matière	Aluminio 6063T5
Espesor aprox. (mm) Approx. thickness / Épaisseur approx / Grossura nominal	3,0
Peso m. lineal (g) Linear m. weight / Poids m. linéaire / Peso linear	2439
Perímetro total (mm) Total perimeter / Périmètre total / Perímetro total	685

■ **Vista explosionada**
Componentes / Composants

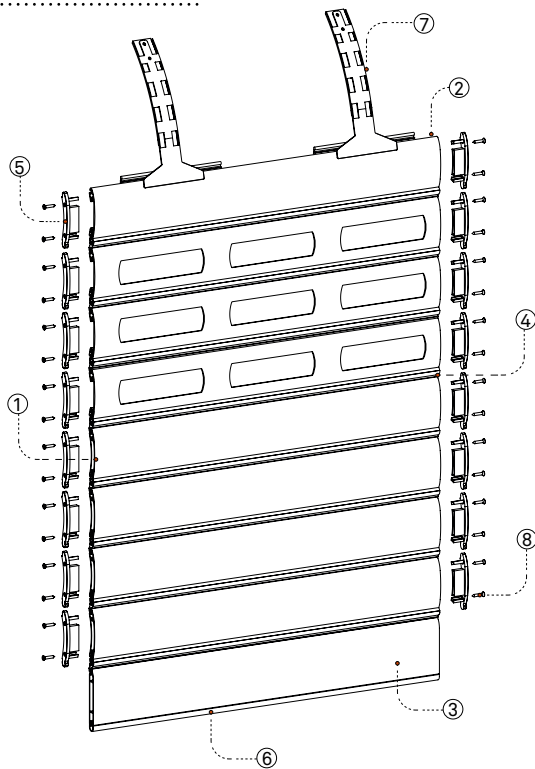

■ **Componentes**
Componentes / Composants

ID	CÓDIGO Code	ARTÍCULOS Articles
1	313192	LAMA DOBLEPARED / Double-skin slat /Lame Double-Paroi
2	313058	LAMA MONOPARED / Single-skin slat /Lame Monoparoi
3	313030	REMATE / End slat / Lame finale
4	313196	VARILLA DE UNIÓN / Middle slat / Lame finale
5	160356	JGO. TAPÓN LATERAL / Pair of end caps of slat / Jeu bouchon lame
6	360026	GOMA REMATE / End slat rubber / Joint lame finale
7	160349	TIRANTE ACERO REVESTIDO / Iron Spring / Attache acier
8	111917	TORNILLO 5,5 x 38 mm DIN 7982 / Screw / Vis

■ **Versiones**
Versions

313194 AL VS-300 BLOCK 95

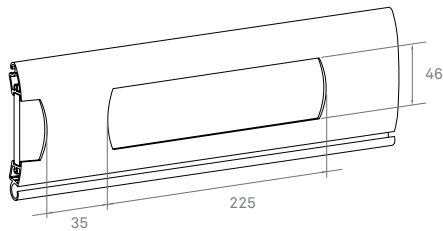

Peso lama troquelada (g/m) Weight / Poids	786
Ventilación (m2/m) Ventilation	0,45

■ **Metacrilato**
Methacrylate / Méthacrylate

311108 VS -150 BLOCK 60 METACRILATO

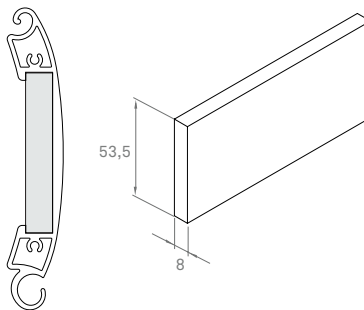

Peso metacrilato (g/m) Weight / Poids	226
--	-----

■ **Tapón compatible**

Compatible side lock / Compatible embout latéra

160356 JGO.TAPÓN AL VS-300 BLOCK 95

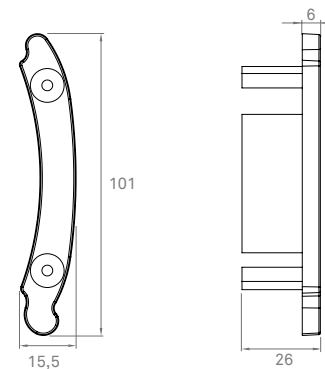

240031 VS-350 BLOCK110

FICHA DE SISTEMA / SYSTEM DATASHEET / FICHE TECHNIQUE DU SYSTÈME / FICHA DE DADOS DO SISTEMA

313198 LAMA AL VS-350 BLOCK 110

Datos técnicos

Technical parameters / Paramètres techniques / Dados técnicos

Material Matière	AL. 6063T5
Lamas por metro de altura Necessary slats per height meter / Nombre de lames au mètre Lâminas por metro de altura	7,7
Superficie de cobertura (mm) Surface coverage / Surface de couverture	129,87
Eje mínimo de enrollamiento Ø (mm) Minimum rolling shaft / Axe minimal d'enroulement / Eixo mínimo de enrolamento	133
Resistencia al viento (Clase) UNE - EN 13241:2004 Wind resistance / Résistance au vent Resistência ao vento	2
Anchura ensayada Tested width / Largeur du tablier testée	4,50 m
Peso m² aprox. Weight per m2 / Poids m ² approximatif	10,3 Kg / m ²
Incremento peso + 30% (Lamas + Varillas unión) para motor Weight increased + 30% (Union slats + slats) for motor Augmentation poids + 30 %	3,08 Kg / m ²

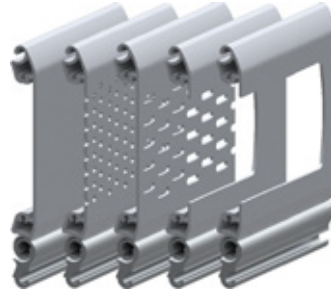

Resistencia al viento según UNE-EN 13241

Wind resistance according to UNE-EN 13241

Résistance au vent conformément à la norme UNE-EN 13241

Clase de Viento

- C1 : 300 Pa ≈ 80 km/h
- C2 : 450 Pa ≈ 98 km/h
- C3 : 700 Pa ≈ 122 km/h
- C4 : 1000 Pa ≈ 145 km/h
- C5 : Mayor a 1000 Pa

Ancho de paño (mm)

Shutter width
Largeur du tablier



4500

Lama

Slats / Lame / Lama

313198 LAMA MONOPARED

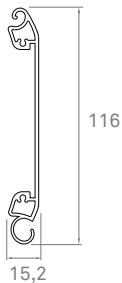

Varilla

Middle slat / Lame intermédiaire

313196 VARILLA UNIÓN



Remate

End slat / Lame finale

313030 REMATE

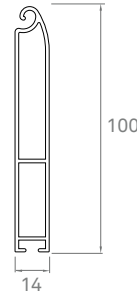

360026 GOMA REMATE

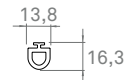

Guía ensayada

Tested guides / Coulisses testées

308205 GUÍA AL GS-130

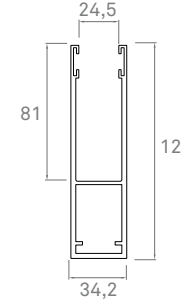

Otras guías compatibles
Other compatible guides
Autres coulisses compatibles

GEM-75
GSO-105

Material Matière	Aluminio 6063T5
Espesor aprox. (mm) Approx. thickness / Épaisseur approx / Grossura nominal	1,8
Peso m. lineal (g) Linear m. weight / Poids m. linéaire / Peso linear	954
Perímetro total (mm) Total perimeter / Périmètre total / Perímetro total	412

Material Matière	Aluminio 6063T5
Espesor aprox. (mm) Approx. thickness / Épaisseur approx / Grossura nominal	2,0
Peso m. lineal (g) Linear m. weight / Poids m. linéaire / Peso linear	384
Perímetro total (mm) Total perimeter / Périmètre total / Perímetro total	116

Material Matière	Aluminio 6063T5
Espesor aprox. (mm) Approx. thickness / Épaisseur approx / Grossura nominal	1,5
Peso m. lineal (g) Linear m. weight / Poids m. linéaire / Peso linear	1007
Perímetro total (mm) Total perimeter / Périmètre total / Perímetro total	487

Material Matière	Aluminio 6063T5
Espesor aprox. (mm) Approx. thickness / Épaisseur approx / Grossura nominal	3,0
Peso m. lineal (g) Linear m. weight / Poids m. linéaire / Peso linear	2439
Perímetro total (mm) Total perimeter / Périmètre total / Perímetro total	685

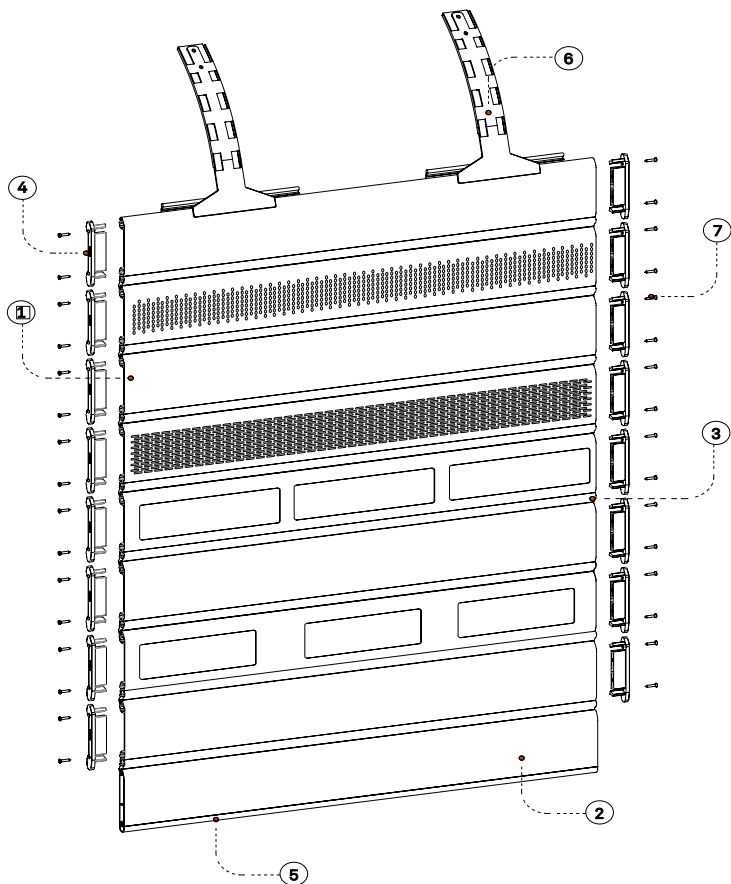

Componentes

Componentes / Composants

ID	CÓDIGO Code	ARTÍCULOS Articles
1	313198	LAMA / Slat / Lame
2	313030	REMATE / End slat / Lame finale
3	313196	VARILLA DE UNIÓN / Middle slat / Lame intermédiaire
4	160357	JGO. TAPÓN LATERAL / Pair of end caps of slat / Jeu bouchon lame
5	360026	GOMA REMATE / End slat rubber / Joint lame finale
6	160349	TIRANTE ACERO REVESTIDO / Iron Spring / Attache acier
7	111880	TORNILLO 3,9 x 25 mm / Screw 3,5 x19 (P103925) / Vis 3,5 x 19 (P103925)

Descuentos

Discounts / Réductions / Descontos

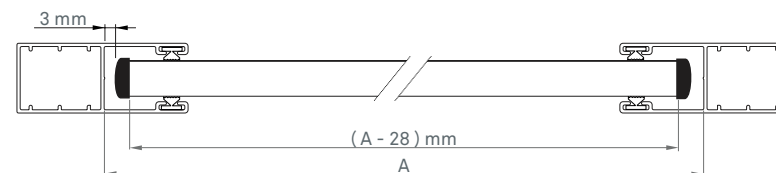

Versiones

Versions

313202 MICROPERFORADA

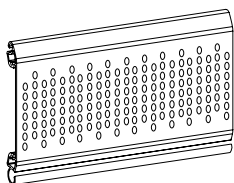

Peso lama perforada (g/m) Weight / Poids	884
Perforación Ø (mm) Perforation	3,5
Ventilación (m2/m) Ventilation	0,08

313200 MICROLUX

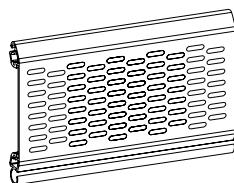

Peso lama perforada (g/m) Weight / Poids	902
Perforación Ø (mm) Perforation	12x3,5
Ventilación (m2/m) Ventilation	0,10

313212 TROQUELADO 180

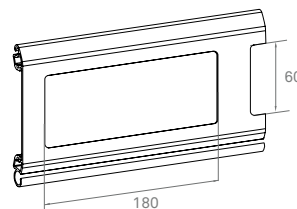

Peso lama troquelada (g/m) Weight / Poids	713
Ventilación (m2/m) Ventilation	0,40

313204 TROQUELADO 390

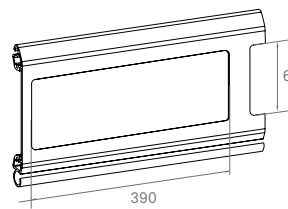

Peso lama troquelada (g/m) Weight / Poids	691
Ventilación (m2/m) Ventilation	0,45

Tapón compatible

Compatible side lock / Compatible embout latéra

160357 TAPÓN LATERAL VS-350 BLOCK 110

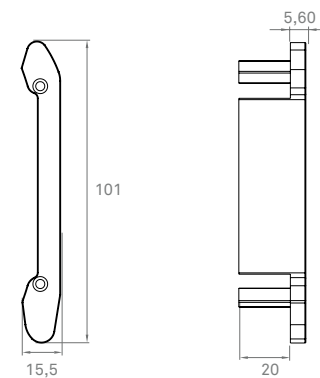

Metacrilato

Methacrylate / Méthacrylate

METACRILATO VS-350

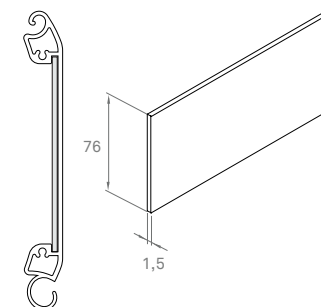

240020 SEGUR EC - 60

FICHA DE SISTEMA / SYSTEM DATASHEET / FICHE TECHNIQUE DU SYSTÈME / FICHA DE DADOS DO SISTEMA

313094 LAMA AL EC - 60 / 313088 LAMA AL EC - 60 TROQUELADA

Datos técnicos

Technical parameters / Paramètres techniques / Dados técnicos

Material Matière	AL. 6063T5
Lamas por metro de altura Necessary slats per height meter / Nombre de lames au mètre / Lâminas por metro de altura	16,6
Superficie de cobertura (mm) Surface coverage / Surface de couverture	60
Eje mínimo de enrollamiento Ø (mm) Minimun rolling shaft / Axe minimal d'enroulement / Eixo mínimo de enrolamento	70
Resistencia al viento (Clase) UNE - EN 13241 Wind resistance / Résistance au vent Resistência ao vento	2
Anchura ensayada Tested width / Largeur du tablier testée	3,00 m
Peso m² aprox. Weight per m2 / Poids m² approximatif	8,15 Kg / m²



Resistencia al viento según UNE-EN 13241

Wind resistance according to UNE-EN 13241

Résistance au vent conformément à la norme UNE-EN 13241

Clase de Viento

- C1 : 300 Pa ≈ 80 km/h
- C2 : 450 Pa ≈ 98 km/h
- C3 : 700 Pa ≈ 122 km/h
- C4 : 1000 Pa ≈ 145 km/h
- C5 : Mayor a 1000 Pa

Ancho de paño (mm)

Shutter width
Largeur du tablier

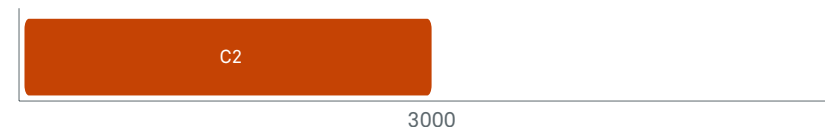

Lama

Slats / Lame / Lama

313094 AL LAMA EC-60

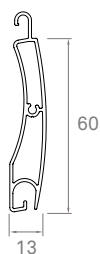

Remate

End slat / Lame finale/ Remate

313066 REMATE INTERIOR

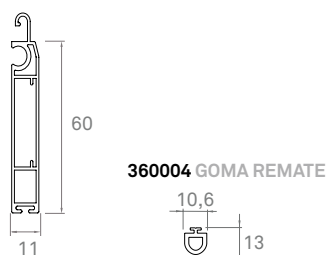

360004 GOMA REMATE

Guía ensayada

Tested guides/ Coulisses testée

308209 GUÍA AL GA-95

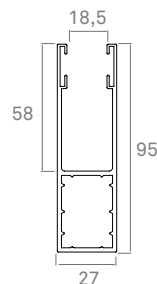

Otras guías compatibles
Other compatible guides
Autres coulisses compatibles

H-76
HC-66

Tapón compatible

Compatible side lock / Compatible embout latéra

111634 JGO TAPON LAMA SEGUR-EC 60

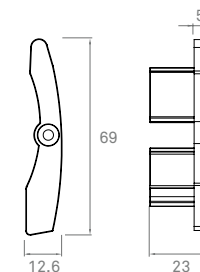

Material Matière	Aluminio 6063T5
Espesor aprox. (mm) Approx. thickness / Épaisseur approx /Grossura nominal	1.0
Peso m. lineal (g) Linear m. weight / Poids m. linéaire / Peso linear	491
Perímetro total (mm) Total perimeter / Périmètre total / Perímetro total	336

Material Matière	Aluminio 6063T5
Espesor aprox. (mm) Approx. thickness / Épaisseur approx /Grossura nominal	1.1
Peso m. lineal (g) Linear m. weight / Poids m. linéaire / Peso linear	564
Perímetro total (mm) Total perimeter / Périmètre total / Perímetro total	364

Material Matière	Aluminio 6063T5
Espesor aprox. (mm) Approx. thickness / Épaisseur approx /Grossura nominal	2.0
Peso m. lineal (g) Linear m. weight / Poids m. linéaire / Peso linear	1302
Perímetro total (mm) Total perimeter / Périmètre total / Perímetro total	532

■ **Vista explosionada**
Componentes / Composants

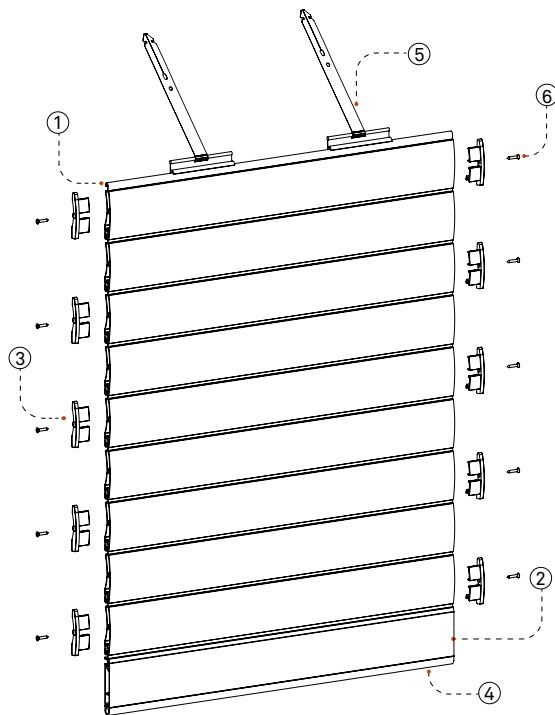

■ **Componentes**
Componentes / Composants

ID	CÓDIGO Code	ARTÍCULOS Articles
1	313094	LAMA DOBLEPARED / Double-skin slat /Lame Double-Paroi
2	313066	REMATE / End slat / Lame finale
3	111634	JGO. TAPÓN LATERAL / Pair of end caps of slat / Jeu bouchon lame
4	360004	GOMA REMATE / End slat rubber / Joint lame finale
5	111355	TIRANTE MET C/TALADROS LAMA SEGUR EC-60 SIN FUNDA / Metallic Spring / Attache métallique
6	111880	TORNILLO 3,9 x 25 mm / Screw / Vis

240029 V-77MONOPARED

FICHA DE SISTEMA / SYSTEM DATASHEET / FICHE TECHNIQUE DU SYSTÈME / FICHA DE DADOS DO SISTEMA

313188 LAMA AL V-77 / 313220 LAMA AL V-77 TROQUELADA - 85

Datos técnicos

Technical parameters / Paramètres techniques / Dados técnicos

Material Matière	AL. 6063T5
Lamas por metro de altura Necessary slats per height meter / Nombre de lames au mètre / Lâminas por metro de altura	13,7
Superficie de cobertura (mm) Surface coverage / Surface de couverture	73
Eje mínimo de enrollamiento Ø (mm) Minimun rolling shaft / Axe minimal d'enroulement / Eixo mínimo de enrolamento	100
Resistencia al viento (Clase) UNE - EN 13241 Wind resistance / Résistance au vent Resistência ao vento	2
Anchura ensayada Tested width / Largeur du tablier testée	4,50
Peso m² aprox. Weight per m2 / Poids m² approximatif	11,3 Kg / m²



Resistencia al viento según UNE-EN 13241

Wind resistance according to UNE-EN 13241

Résistance au vent conformément à la norme UNE-EN 13241

Clase de Viento

- C1 : 300 Pa ≈ 80 km/h
- C2 : 450 Pa ≈ 98 km/h
- C3 : 700 Pa ≈ 122 km/h
- C4 : 1000 Pa ≈ 145 km/h
- C5 : Mayor a 1000 Pa

Ancho de paño (mm)

Shutter width
Largeur du tablier



Lama

Slats / Lame / Lama

313188 AL LAMA V-77

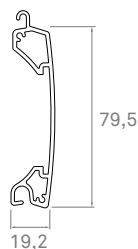

Material Matière	Aluminio 6063T5
Espesor aprox. (mm) Approx. thickness / Épaisseur approx / Grossura nominal	1,7
Peso m. lineal (g) Linear m. weight / Poids m. linéaire / Peso linear	831
Perímetro total (mm) Total perimeter / Périmètre total / Perímetro total	359

Remate

End slat / Lame finale/ Remate

313118 REMATE AL V-77

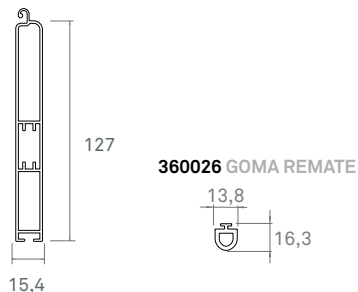

Material Matière	Aluminio 6063T5
Espesor aprox. (mm) Approx. thickness / Épaisseur approx / Grossura nominal	1.5
Peso m. lineal (g) Linear m. weight / Poids m. linéaire / Peso linear	1355
Perímetro total (mm) Total perimeter / Périmètre total / Perímetro total	662

Guía ensayada

Tested guides/ Coulisses testée

308205 GUÍA AL GS-130

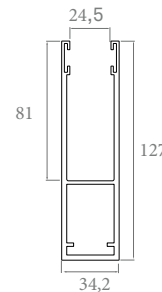

Material Matière	Aluminio 6063T5
Espesor aprox. (mm) Approx. thickness / Épaisseur approx / Grossura nominal	3.0
Peso m. lineal (g) Linear m. weight / Poids m. linéaire / Peso linear	2439
Perímetro total (mm) Total perimeter / Périmètre total / Perímetro total	686

Tapón compatible

Compatible side lock / Compatible embout latéra

160439 JGO. TAPÓN LATERAL V-77

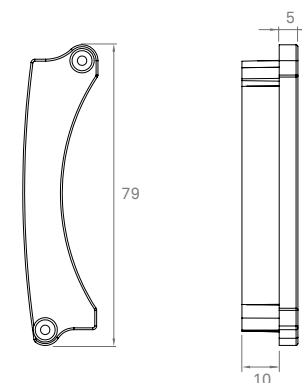

Otras guías compatibles
Other compatible guides
Autres coulisses compatibles

GS - 100, GSR - 66,
GEM - 65, PRM. 80X80

■ **Vista explosionada**
Componentes / Composants

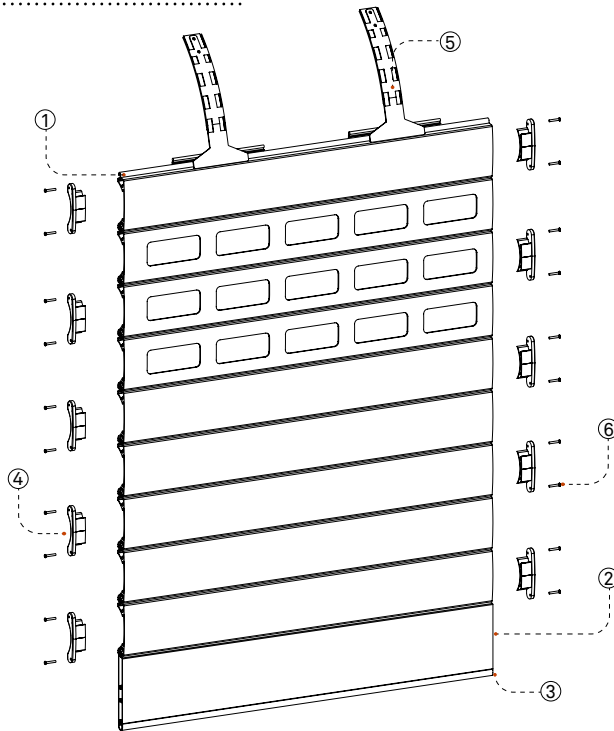

■ **Componentes**
Componentes / Composants

ID	CÓDIGO Code	ARTÍCULOS Articles
1	313188	LAMA / Slat /Lame
2	313118	REMATE / End slat / Lame finale
3	360026	GOMA REMATE / End slat rubber / Joint lame finale
4	160439	JGO. TAPÓN LAMA / Pair of end caps / Jeu bouchon
5	160344	TIRANTE ACERO REVESTIDO / Iron Spring / Attache métallique
6	111880	TORNILLO 3,9 x 25 mm / Screw / Vis

■ **Versiones**

Versions

313220 LAMA V-77 TROQUELADA - 85

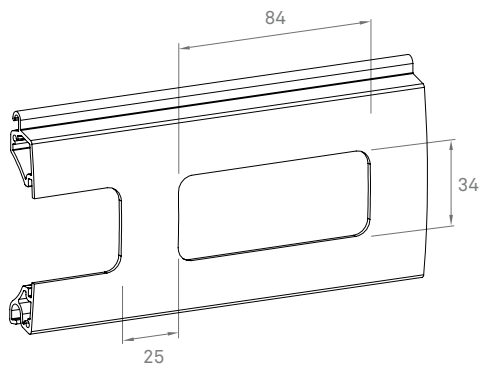

Peso lama perforada (g/m) Weight / Poids	715
Ventilación (m2/m) Ventilation	0,39

240022 V-80 DOBLEPARED

FICHA DE SISTEMA / SYSTEM DATASHEET / FICHE TECHNIQUE DU SYSTÈME / FICHA DE DADOS DO SISTEMA

313144 LAMA AL V-80 DOBLEPARED / 313142 LAMA AL V-80 MONOPARED

Datos técnicos

Technical parameters / Paramètres techniques / Dados técnicos

Material Matière	AL. 6063T5
Lamas por metro de altura Necessary slats per height meter / Nombre de lames au mètre / Lâminas por metro de altura	12,5
Superficie de cobertura (mm) Surface coverage / Surface de couverture	80
Eje mínimo de enrollamiento Ø (mm) Minimun rolling shaft / Axe minimal d'enroulement / Eixo mínimo de enrolamento	100
Resistencia al viento (Clase) UNE - EN 13241 Wind resistance / Résistance au vent / Resistência ao vento	2
Anchura ensayada Tested width / Largeur du tablier testée	5,50 m
Peso m² aprox. Weight per m2 / Poids m² approximatif	10,9 Kg / m²



Resistencia al viento según UNE-EN 13241

Wind resistance according to UNE-EN 13241

Résistance au vent conformément à la norme UNE-EN 13241

Clase de Viento

- C1 : 300 Pa ≈ 80 km/h
- C2 : 450 Pa ≈ 98 km/h
- C3 : 700 Pa ≈ 122 km/h
- C4 : 1000 Pa ≈ 145 km/h
- C5 : Mayor a 1000 Pa

Ancho de paño (mm)

Shutter width
Largeur du tablier



Lama

Slats / Lame / Lama

313144 AL V-80 DOBLEPARED

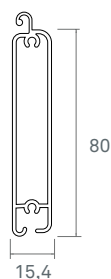

Lama

Slats / Lame / Lama

313142 AL V-80 MONOPARED



Remate

End slat / Lame finale/ Remate

313118 REMATE AL V-80

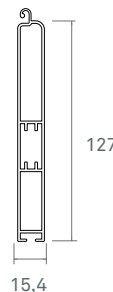

360026 GOMA REMATE

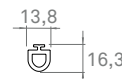

Guia ensayada

Tested guides/ Coulisses testée

308205 GUÍA AL GS-130

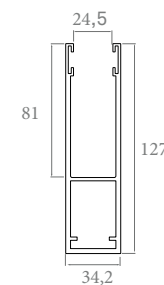

Material Matière	Aluminio 6063T5
Espesor aprox. (mm) Approx. thickness /Épaisseur approx /Grossura nominal	1,6
Peso m. lineal (g) Linear m. weight / Poids m. linéaire / Peso linear	878
Perímetro total (mm) Total perimeter / Périmètre total / Perímetro total	436

Material Matière	Aluminio 6063T5
Espesor aprox. (mm) Approx. thickness /Épaisseur approx /Grossura nominal	2.0
Peso m. lineal (g) Linear m. weight / Poids m. linéaire / Peso linear	800
Perímetro total (mm) Total perimeter / Périmètre total / Perímetro total	344

Material Matière	Aluminio 6063T5
Espesor aprox. (mm) Approx. thickness /Épaisseur approx /Grossura nominal	1.5
Peso m. lineal (g) Linear m. weight / Poids m. linéaire / Peso linear	1355
Perímetro total (mm) Total perimeter / Périmètre total / Perímetro total	662

Material Matière	Aluminio 6063T5
Espesor aprox. (mm) Approx. thickness /Épaisseur approx /Grossura nominal	3.0
Peso m. lineal (g) Linear m. weight / Poids m. linéaire / Peso linear	2439
Perímetro total (mm) Total perimeter / Périmètre total / Perímetro total	686

Otras guías compatibles
Other compatible guides
Autres coulisses compatibles

SE - 55, GS - 100, GSR - 66, GEM - 65, PRM. 80X80, PRM. 105X80

■ **Vista explosionada**
Componentes / Composants

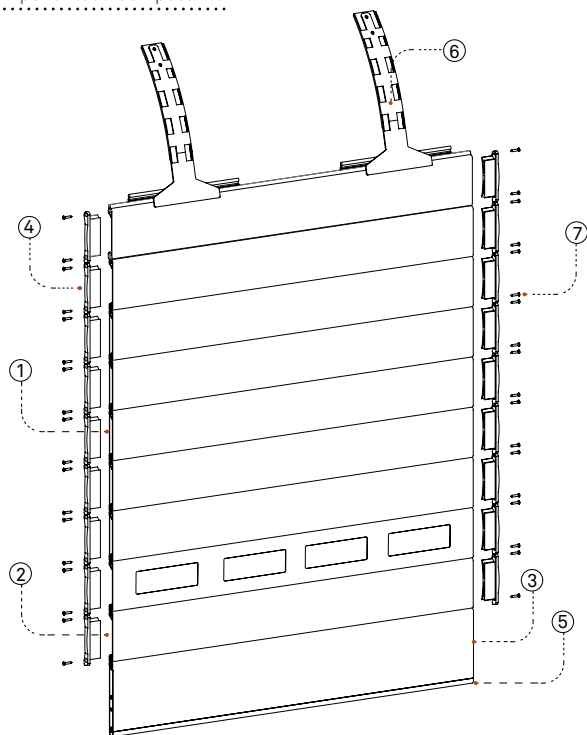

■ **Componentes**
Componentes / Composants

ID	CÓDIGO Code	ARTÍCULOS Articles
1	313144	LAMA DOBLEPARED / Slat /Lame
2	313142	LAMA MONOPARED / Slat /Lame
3	313118	REMATE / End slat / Lame finale
4	160307	JGO. TAPÓN LATERAL / Pair of end caps of slat / Jeu bouchon lame
5	360026	GOMA REMATE / End slat rubber / Joint lame finale
6	160344	TIRANTE FLEJE / Iron Spring / Attache métallique
7	111880	TORNILLO 3,9 x 25 mm / Screw / Vis

■ **Versiones**
Versions

313146 TROQUELADA 85

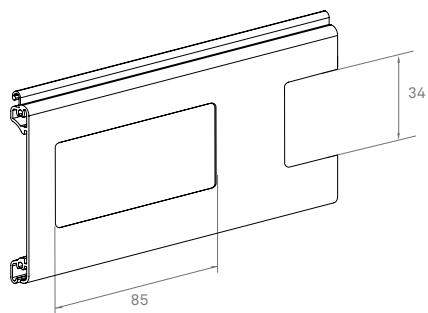

Peso lama perforada (g/m) Weight / Poids	876
Perforación Perforation	12x3,5
Ventilación (m2/m) Ventilation	0,40

■ **Tapón compatible**

Compatible side lock / Compatible embout latéra

160307 TAPÓN LATERAL V-80

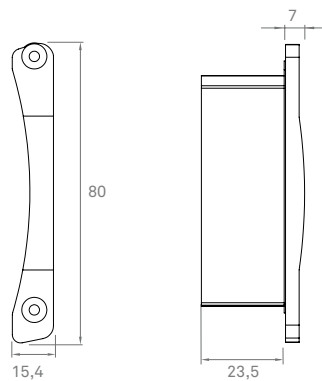

240016 ECOSEGUR - 100

FICHA DE SISTEMA / SYSTEM DATASHEET / FICHE TECHNIQUE DU SYSTÈME / FICHA DE DADOS DO SISTEMA

313096 LAMA AL ECOSEGUR -100

Datos técnicos

Technical parameters / Paramètres techniques / Dados técnicos

Material Matière	AL. 6063T5
Lamas por metro de altura Necessary slats per height meter / Nombre de lames au mètre / Lâminas por metro de altura	10
Superficie de cobertura (mm) Surface coverage / Surface de couverture	100
Eje mínimo de enrollamiento Ø (mm) Minimun rolling shaft / Axe minimal d'enroulement / Eixo mínimo de enrolamento	100
Resistencia al viento (Clase) UNE - EN 13241 Wind resistance / Résistance au vent Resistência ao vento	-
Anchura ensayada Tested width / Largeur du tablier testée	-
Peso m² aprox. Weight per m2 / Poids m² approximatif	7,33 Kg / m²

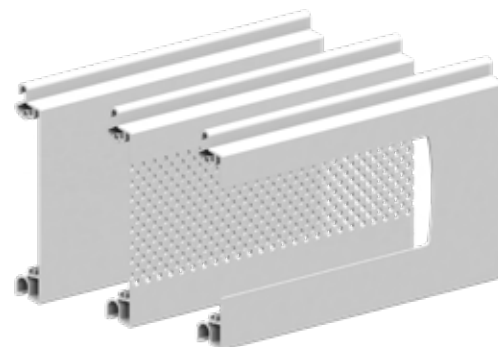

Resistencia al viento según UNE-EN 13241

Wind resistance according to UNE-EN 13241

Résistance au vent conformément à la norme UNE-EN 13241

Clase de Viento

- C1 : 300 Pa ≈ 80 km/h
- C2 : 450 Pa ≈ 98 km/h
- C3 : 700 Pa ≈ 122 km/h
- C4 : 1000 Pa ≈ 145 km/h
- C5 : Mayor a 1000 Pa

Ancho de paño (mm)

Shutter width
Largeur du tablier



Lama

Slats / Lame / Lama

313096 AL ECOSEGUR -100

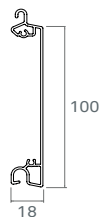

Remate

End slat / Lame finale/ Remate

313038 REMATE AL ECOSEGUR - 100

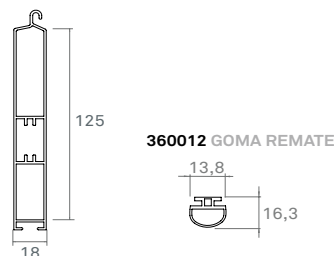

Guía ensayada

Tested guides/ Coulisses testée.

308202 GUÍA AL GS-100

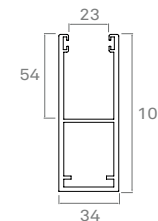

Material Matière	Aluminio 6063T5
Espesor aprox. (mm) Approx. thickness /Épaisseur approx /Grossura nominal	1,3
Peso m. lineal (g) Linear m. weight / Poids m. linéaire / Peso linear	733,5
Perímetro total (mm) Total perimeter / Périmètre total / Perímetro total	410,8

Material Matière	Aluminio 6063T5
Espesor aprox. (mm) Approx. thickness /Épaisseur approx /Grossura nominal	1,35
Peso m. lineal (g) Linear m. weight / Poids m. linéaire / Peso linear	705,4
Perímetro total (mm) Total perimeter / Périmètre total / Perímetro total	650

Material Matière	Aluminio 6063T5
Espesor aprox. (mm) Approx. thickness /Épaisseur approx /Grossura nominal	2,8
Peso m. lineal (g) Linear m. weight / Poids m. linéaire / Peso linear	1978
Perímetro total (mm) Total perimeter / Périmètre total / Perímetro total	568,4

■ **Vista explosionada**
Componentes / Composants

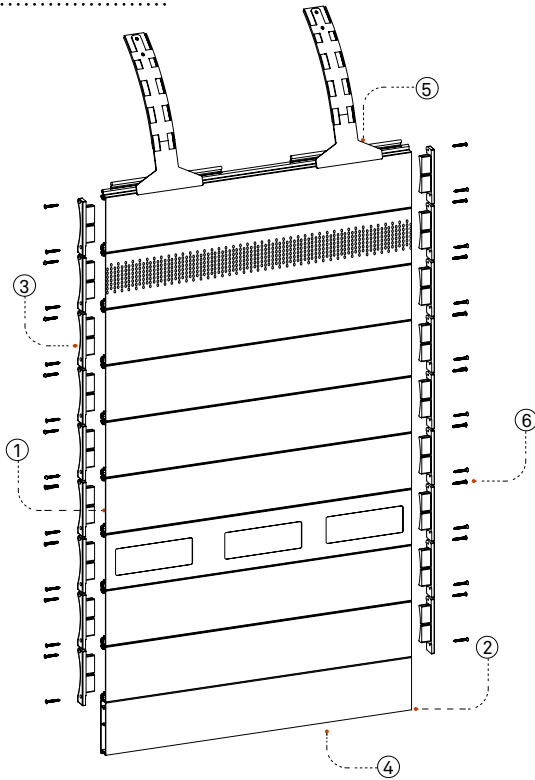

■ **Componentes**
Componentes / Composants

ID	CÓDIGO Code	ARTÍCULOS Articles
1	313096	LAMA / Slat /Lame
2	313038	REMATE / End slat / Lame finale
3	160080	JGO. TAPÓN LATERAL / Pair of end caps of slat / Jeu bouchon lame
4	360012	GOMA REMATE / End slat rubber / Joint lame finale
5	160344	TIRANTE ACERO REVESTIDO / Iron Spring / Attache acier
6	111565	TORNILLO 3.5X32 DIN 7982m / Screw / Vis

■ **Versiones**
Versions

313182 MICROPERFORADA

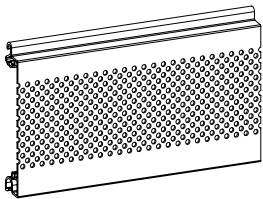

Peso lama perforada (g/m) Weight / Poids	666
Perforación Ø (mm) Perforation	3,5
Ventilación (m2/m) Ventilation	0,24

313186 TROQUELADO 180

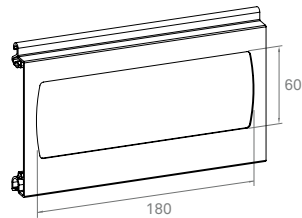

Peso lama perforada (g/m) Weight / Poids	576
Ventilación (m2/m) Ventilation	0,57

■ **Metacrilato**
Methacrylate / Méthacrylate

311008 POLICARBONATO ECOSEGUR-100 (84x1,5)

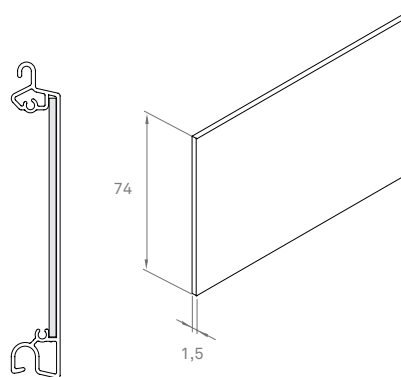

■ **Tapón compatible**

Compatible side lock / Compatible embout latéra

160080 TAPÓN LATERAL

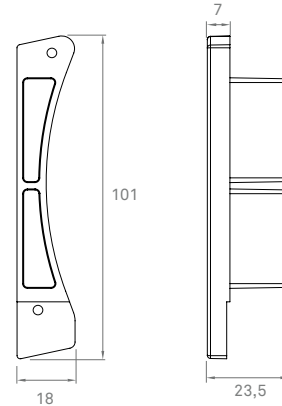

240024 V-100 MONOPARED

FICHA DE SISTEMA / SYSTEM DATASHEET / FICHE TECHNIQUE DU SYSTÈME / FICHA DE DADOS DO SISTEMA

313150 LAMA AL V-100 MONOPARED

Datos técnicos

Technical parameters / Paramètres techniques / Dados técnicos

Material Matière	AL. 6063T5
Lamas por metro de altura Necessary slats per height meter / Nombre de lames au mètre / Lâminas por metro de altura	10
Superficie de cobertura (mm) Surface coverage / Surface de couverture	100
Eje mínimo de enrollamiento Ø (mm) Minimun rolling shaft / Axe minimal d'enroulement / Eixo mínimo de enrolamento	100
Resistencia al viento (Clase) UNE - EN 13241 Wind resistance / Résistance au vent Resistência ao vento	2
Anchura ensayada Tested width / Largeur du tablier testée	4,50
Peso m² aprox. Weight per m2 / Poids m² approximatif	9,64 Kg / m²

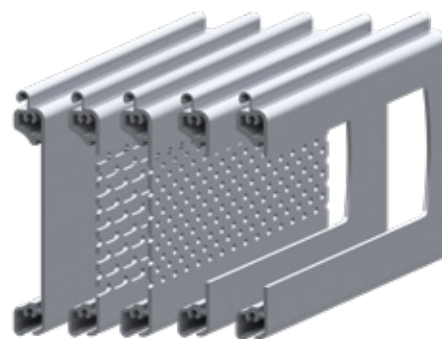

Resistencia al viento según UNE-EN 13241

Wind resistance according to UNE-EN 13241

Résistance au vent conformément à la norme UNE-EN 13241

Clase de Viento

- C1 : 300 Pa ≈ 80 km/h
- C2 : 450 Pa ≈ 98 km/h
- C3 : 700 Pa ≈ 122 km/h
- C4 : 1000 Pa ≈ 145 km/h
- C5 : Mayor a 1000 Pa

Ancho de paño (mm)

Shutter width
Largeur du tablier



Lama

Slats / Lame / Lama

313150 AL V-100 MONOPARED



Material Matière	Aluminio 6063T5
Espesor aprox. (mm) Approx. thickness / Épaisseur approx / Grossura nominal	2.0
Peso m. lineal (g) Linear m. weight / Poids m. linéaire / Peso linear	964
Perímetro total (mm) Total perimeter / Périmètre total / Perímetro total	384

Remate

End slat / Lame finale/ Remate

313118 REMATE AL V-100

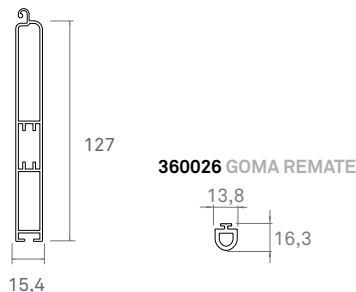

Material Matière	Aluminio 6063T5
Espesor aprox. (mm) Approx. thickness / Épaisseur approx / Grossura nominal	1.5
Peso m. lineal (g) Linear m. weight / Poids m. linéaire / Peso linear	1355
Perímetro total (mm) Total perimeter / Périmètre total / Perímetro total	662

Guía ensayada

Tested guides/ Coulisses testée

308205 GUÍA AL GS-130

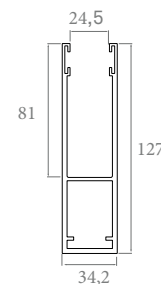

Material Matière	Aluminio 6063T5
Espesor aprox. (mm) Approx. thickness / Épaisseur approx / Grossura nominal	3.0
Peso m. lineal (g) Linear m. weight / Poids m. linéaire / Peso linear	2439
Perímetro total (mm) Total perimeter / Périmètre total / Perímetro total	686

Otras guías compatibles
Other compatible guides
Autres coulisses compatibles

SE - 55, GS - 100, GSR - 66, GEM - 65,
PRM. 80X80, PRM. 105X80

Vista explosionada
Componentes / Composants

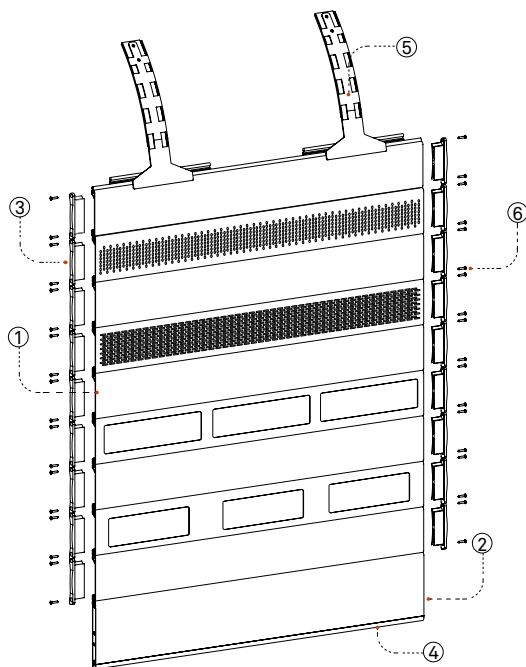

Componentes
Componentes / Composants

ID	CÓDIGO Code	ARTÍCULOS Articles
1	313150	LAMA / Slat /Lame
2	313118	REMATE / End slat / Lame finale
3	160351	JGO. TAPÓN LATERAL / Pair of end caps of slat / Jeu bouchon lame
4	360026	GOMA REMATE / End slat rubber / Joint lame finale
5	160344	TIRANTE ACERO REVESTIDO / Iron Spring / Attache métallique
6	111880	TORNILLO 3,9 x 25 mm / Screw / Vis

Versiones
Versions

313168 MICROPERFORADA

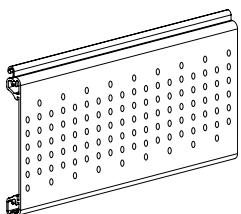

Peso lama perforada (g/m) Weight / Poids	874
Perforación Ø (mm) Perforation	3,5
Ventilación (m2/m) Ventilation	0,25

313164 MICROLUX

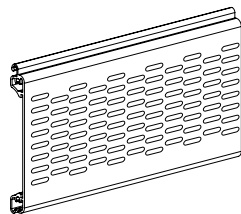

Peso lama perforada (g/m) Weight / Poids	876
Perforación Ø (mm) Perforation	12x3,5
Ventilación (m2/m) Ventilation	0,24

313174 TROQUELADO 180

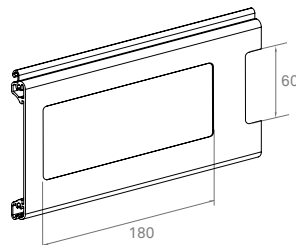

Peso lama perforada (g/m) Weight / Poids	665
Ventilación (m2/m) Ventilation	0,57

313172 TROQUELADO 390

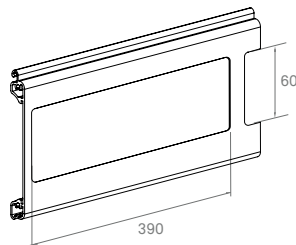

Peso lama perforada (g/m) Weight / Poids	651
Ventilación (m2/m) Ventilation	0,67

Metacrilato

Methacrylate / Méthacrylate

TROQUEL 180 + METACRILATO

TROQUEL 390 + METACRILATO

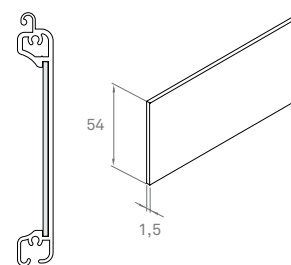

Peso metacrilato (g / m) Weight / Poids	65
--	----

Tapón compatible

Compatible side lock / Compatible embout latéra

160351 JGO. TAPÓN LATERAL V-100

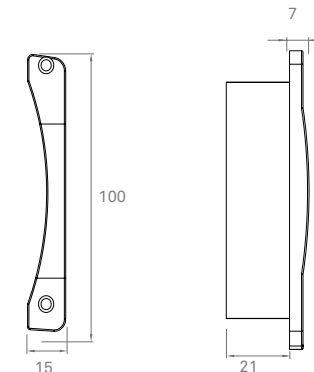

240035 V-100 HARMONY

FICHA DE SISTEMA / SYSTEM DATASHEET / FICHE TECHNIQUE DU SYSTÈME / FICHA DE DADOS DO SISTEMA

313229 LAMA AL V-100 HARMONY / 313230 LAMA AL V-100 HARMONY BRUTO

Datos técnicos

Technical parameters / Paramètres techniques / Dados técnicos

Material Matière	AL. 6063T5	
Lamas por metro de altura Necessary slats per height meter / Nombre de lames au mètre / Lâminas por metro de altura	10	
Superficie de cobertura (mm) Surface coverage / Surface de couverture	100	
Eje mínimo de enrollamiento Ø (mm) Minimum rolling shaft / Axe minimal d'enroulement / Eixo mínimo de enrolamento	100	
Resistencia al viento (Clase) UNE - EN 13241 Wind resistance / Résistance au vent / Resistência ao vento	2 GEM-65	2 GS-130
Anchura ensayada Tested width / Largeur du tablier testée	3,40 m	4,35 m
Peso m² aprox. Weight per m2 / Poids m² approximatif	9,74 Kg / m²	



Resistencia al viento según UNE-EN 13241

Wind resistance according to UNE-EN 13241

Résistance au vent conformément à la norme UNE-EN 13241

Clase de Viento

- C1 : 300 Pa ≈ 80 km/h
- C2 : 450 Pa ≈ 98 km/h
- C3 : 700 Pa ≈ 122 km/h
- C4 : 1000 Pa ≈ 145 km/h
- C5 : Mayor a 1000 Pa

Ancho de paño (mm)

Shutter width
Largeur du tablier

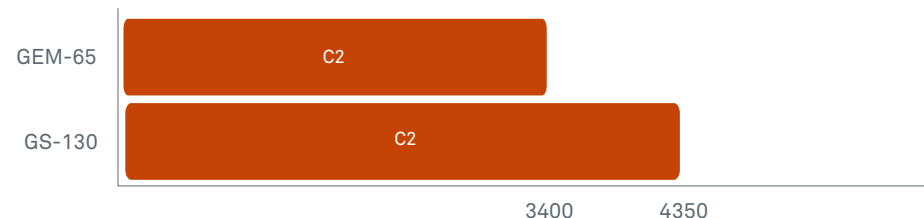

Lama

Slats / Lame / Lama

313229 AL V-100 HARMONY

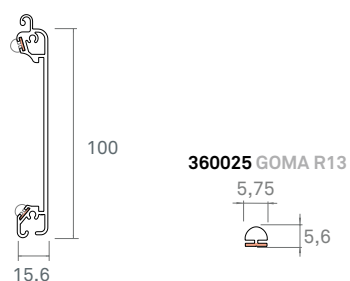

360025 GOMA R13

Remate

End slat / Lame finale/ Remate

313118 REMATE AL V-100

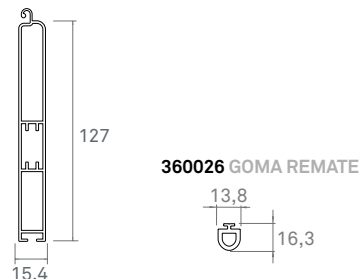

360026 GOMA REMATE

Guía ensayada

Tested guides/ Coulisses testée

308205 GUÍA AL GS-130

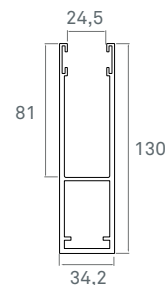

308211 GUÍA AL GEM - 65

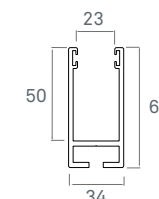

Otras guías compatibles
Other compatible guides
Autres coulisses compatibles

GSR - 66, GS - 100,
PRM. 80X80, PRM. 105X80

Material Matière	Aluminio 6063T5
Espesor aprox. (mm) Approx. thickness / Épaisseur approx /Grossura nominal	2.0
Peso m. lineal con gomas (g) Linear m. weight / Poids m. linéaire / Peso linear	974
Perímetro total (mm) Total perimeter / Périmètre total / Perímetro total	398

Material Matière	Aluminio 6063T5
Espesor aprox. (mm) Approx. thickness / Épaisseur approx /Grossura nominal	1.5
Peso m. lineal (g) Linear m. weight / Poids m. linéaire / Peso linear	1355
Perímetro total (mm) Total perimeter / Périmètre total / Perímetro total	662

Material Matière	Aluminio 6063T5
Espesor aprox. (mm) Approx. thickness / Épaisseur approx /Grossura nominal	3.0
Peso m. lineal (g) Linear m. weight / Poids m. linéaire / Peso linear	2439
Perímetro total (mm) Total perimeter / Périmètre total / Perímetro total	686

Material Matière	Aluminio 6063T5
Espesor aprox. (mm) Approx. thickness / Épaisseur approx /Grossura nominal	2.8
Peso m. lineal (g) Linear m. weight / Poids m. linéaire / Peso linear	1398
Perímetro total (mm) Total perimeter / Périmètre total / Perímetro total	393

■ **Vista explosionada**
Componentes / Composants

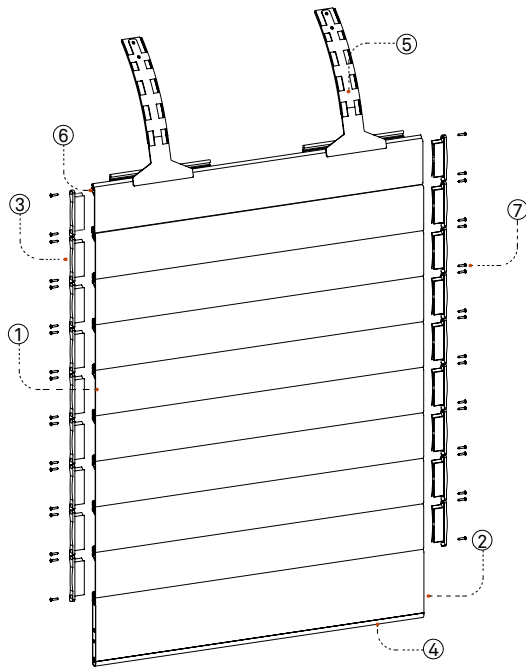

■ **Componentes**
Componentes / Composants

ID	CÓDIGO Code	ARTÍCULOS Articles
1	313150	LAMA / Slat /Lame
2	313118	REMATE / End slat / Lame finale
3	160351	JGO. TAPÓN LATERAL / Pair of end caps of slat / Jeu bouchon lame
4	360026	GOMA REMATE / End slat rubber / Joint lame finale
5	160344	TIRANTE ACERO REVESTIDO / Iron Spring / Attache métallique
6	360025	GOMA R13/ Slat rubber / Joint lame
7	111880	TORNILLO 3,9 x 25 mm / Screw / Vis

■ **Tapón compatible**
Compatible side lock / Compatible embout latéra

160351 JGO. TAPÓN LATERAL V-100

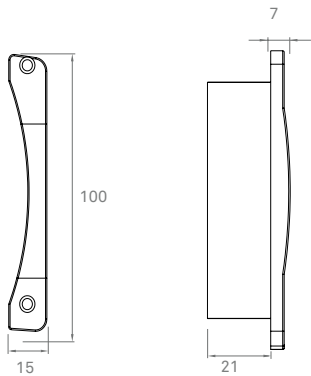

241003 V-77 PF

FICHA DE SISTEMA / SYSTEM DATASHEET / FICHE TECHNIQUE DU SYSTÈME / FICHA DE DADOS DO SISTEMA

312003 ALV-77 PF

NOTA: NO compatible puerta farmacia.

Datos técnicos

Technical parameters / Paramètres techniques / Dados técnicos

Material Matière	AL. 6063T5
Lamas por metro de altura Necessary slats per height meter / Nombre de lames au mètre / Lâminas por metro de altura	13
Superficie de cobertura (mm) Surface coverage / Surface de couverture	77
Eje mínimo de enrollamiento Ø (mm) Minimun rolling shaft / Axe minimal d'enroulement / Eixo mínimo de enrolamento	100
Resistencia al viento (Clase) UNE - EN 13241 Wind resistance / Résistance au vent Resistência ao vento	2
Anchura ensayada Tested width / Largeur du tablier testée	3,50 m
Peso m² aprox. Weight per m2 / Poids m² approximatif	5,5 Kg / m²



Resistencia al viento según UNE-EN 13241

Wind resistance according to UNE-EN 13241

Résistance au vent conformément à la norme UNE-EN 13241

Clase de Viento

- C1 : 300 Pa ≈ 80 km/h
- C2 : 450 Pa ≈ 98 km/h
- C3 : 700 Pa ≈ 122 km/h
- C4 : 1000 Pa ≈ 145 km/h
- C5 : Mayor a 1000 Pa

Ancho de paño (mm)

Shutter width
Largeur du tablier



Lama

Slats / Lame / Lama

312003 ALV-77 PF

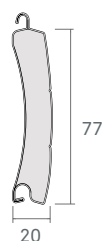

Remate

End slat / Lame finale/ Remate

313208 REMATE AL UNIV.

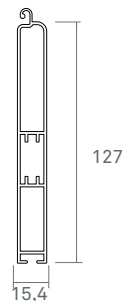

360026 GOMA REMATE

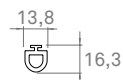

Guía ensayada

Tested guides/ Coulisses testée

308205 GUÍA AL GS-130

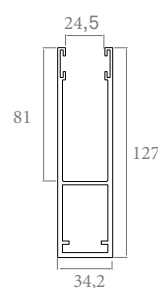

Otras guías compatibles
Other compatible guides
Autres coulisses compatibles

GS - 100,
GSR - 66
GEM - 65,
PRM. 80X80

Tapón compatible

Compatible side lock / Compatible embout latéra

160082 JGO TAPON LAMA PF77

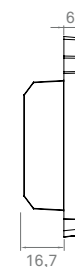
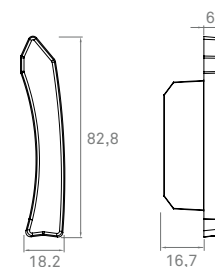

Material Matière	Aluminio 6063T5
Espesor aprox. (mm) Approx. thickness / Épaisseur approx / Grossura nominal	2,0
Peso m. lineal (g) Linear m. weight / Poids m. linéaire / Peso linear	423
Perímetro total (mm) Total perimeter / Périmètre total / Perímetro total	261

Material Matière	Aluminio 6063T5
Espesor aprox. (mm) Approx. thickness / Épaisseur approx / Grossura nominal	1,5
Peso m. lineal (g) Linear m. weight / Poids m. linéaire / Peso linear	1339
Perímetro total (mm) Total perimeter / Périmètre total / Perímetro total	992

Material Matière	Aluminio 6063T5
Espesor aprox. (mm) Approx. thickness / Épaisseur approx / Grossura nominal	3.0
Peso m. lineal (g) Linear m. weight / Poids m. linéaire / Peso linear	2439
Perímetro total (mm) Total perimeter / Périmètre total / Perímetro total	686

■ **Vista explosionada**
Componentes / Composants

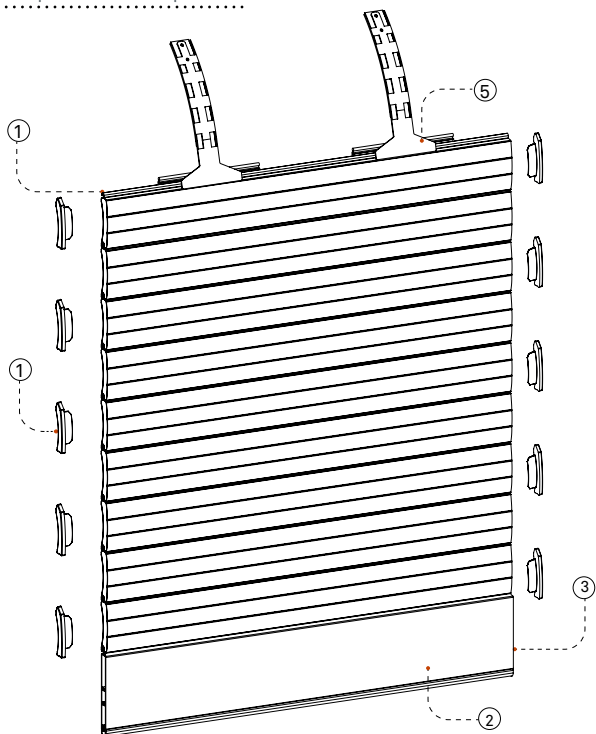

■ **Componentes**
Componentes / Composants

ID	CÓDIGO Code	ARTÍCULOS Articles
1	312003	LAMA / Slat /Lame
2	313118	REMATE / End slat / Lame finale
3	360026	GOMA REMATE / End slat rubber / Joint lame finale
4	160082	JGO. TAPÓN LAMA / Pair of end caps / Jeu bouchon
5	160344	TIRANTE FLEJE / Iron Spring / Attache métallique

240020 SEGUR EC - 60 EXTREME

FICHA DE SISTEMA / SYSTEM DATASHEET / FICHE TECHNIQUE DU SYSTÈME / FICHA DE DADOS DO SISTEMA

313094 LAMA AL EC-60

Datos técnicos

Technical parameters / Paramètres techniques / Dados técnicos

Material Matière	AL. 6063T5	
Lamas por metro de altura Necessary slats per height meter / Nombre de lames au mètre / Lâminas por metro de altura	16,6	
Superficie de cobertura (mm) Surface coverage / Surface de couverture	60	
Eje mínimo de enrollamiento Ø (mm) Minimun rolling shaft / Axe minimal d'enroulement / Eixo mínimo de enrolamento	70	
Resistencia al viento (Clase) UNE - EN 13241 Wind resistance / Résistance au vent / Resistência ao vento	5+ 4106 Pa	5
Anchura ensayada Tested width / Largeur du tablier testée	2,50 m	4,25 m
Peso m² aprox. Weight per m2 / Poids m² approximatif	8,15 Kg / m²	



Resistencia al viento según UNE-EN 13241

Wind resistance according to UNE-EN 13241

Résistance au vent conformément à la norme UNE-EN 13241

Clase de Viento

- C1 : 300 Pa ≈ 80 km/h
- C2 : 450 Pa ≈ 98 km/h
- C3 : 700 Pa ≈ 122 km/h
- C4 : 1000 Pa ≈ 145 km/h
- C5 : Mayor a 1000 Pa

Ancho de paño (mm)

Shutter width
Largeur du tablier

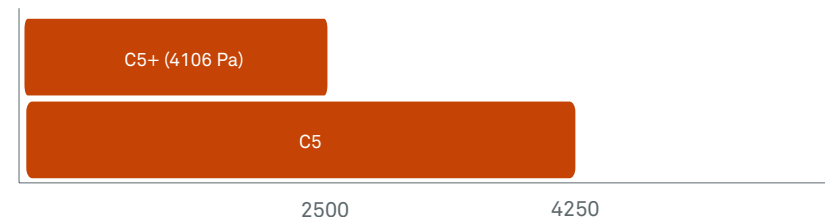

Lama

Slats / Lame / Lama

313094 AL LAMA EC-60

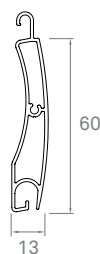

Remate

End slat / Lame finale/ Remate

313066 REMATE INTERIOR

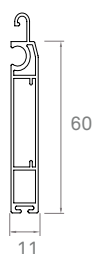

360004 GOMA REMATE

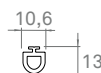

Guia ensayada

Tested guides/ Coulisses testée

308196 GUIA AL EXTREME

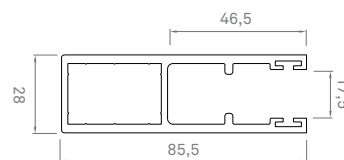

Tapón compatible

Compatible side lock / Compatible embout latéra

160001 JGO.TAPÓN AL SEGUR EC - 60

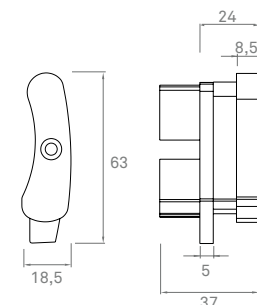

Material Matière	Aluminio 6063T5
Espesor aprox. (mm) Approx. thickness / Épaisseur approx / Grossura nominal	1.0
Peso m. lineal (g) Linear m. weight / Poids m. linéaire / Peso linear	491
Perímetro total (mm) Total perimeter / Périmètre total / Perímetro total	336

Material Matière	Aluminio 6063T5
Espesor aprox. (mm) Approx. thickness / Épaisseur approx / Grossura nominal	1.1
Peso m. lineal (g) Linear m. weight / Poids m. linéaire / Peso linear	564
Perímetro total (mm) Total perimeter / Périmètre total / Perímetro total	364

Material Matière	Aluminio 6063T5
Espesor aprox. (mm) Approx. thickness / Épaisseur approx / Grossura nominal	3.0
Peso m. lineal (g) Linear m. weight / Poids m. linéaire / Peso linear	1790
Perímetro total (mm) Total perimeter / Périmètre total / Perímetro total	487

■ **Vista explosionada**
Componentes / Composants

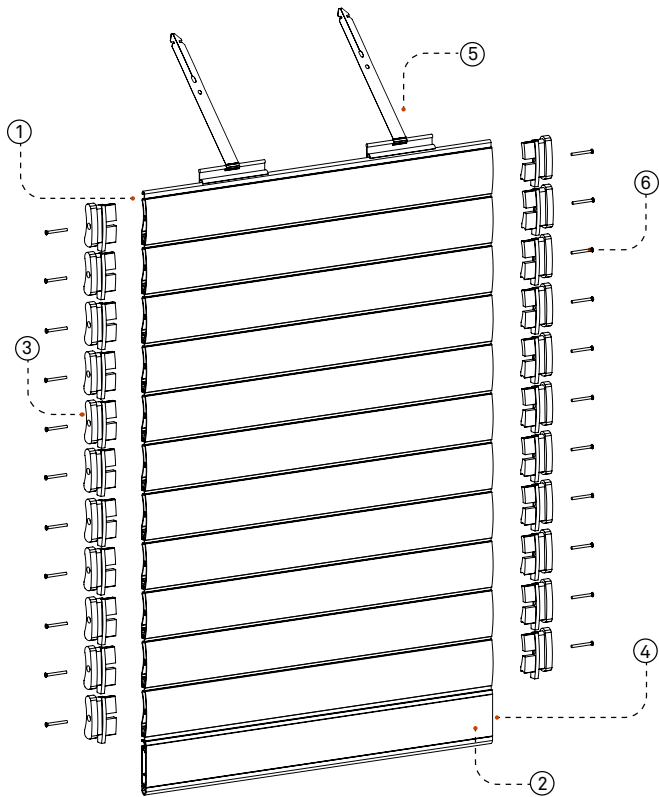

■ **Componentes**
Componentes / Composants

ID	CÓDIGO Code	ARTÍCULOS Articles
1	313094	LAMA / Slat /Lame
2	313066	REMATE / End slat / Lame finale
3	160001	JGO. TAPÓN LATERAL EXTREME / Pair of end caps of slat / Jeu bouchon lame
4	360004	GOMA REMATE / End slat rubber / Joint lame finale
5	111355	TIRANTE MET C/TALADROS LAMA SEGUR EC-60 SIN FUNDA / Metallic Spring / Attache métallique
6	111565	TORNILLO 3,5 x 32 mm / Screw / Vis

■ **Descuentos**
Discounts / Réductions / Descontos

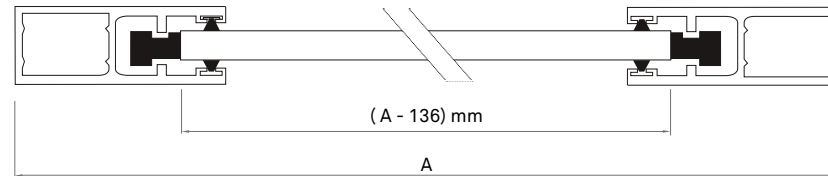

11nan
PREMIOS
arquitectura y construcción

PRODUCTO GANADOR

240017 SEGUR EC-60 EXTREME

PERSAX S23

240033 V-100 MONOPARED EXTREME

FICHA DE SISTEMA / SYSTEM DATASHEET / FICHE TECHNIQUE DU SYSTÈME / FICHA DE DADOS DO SISTEMA

313150 LAMA AL V-100 MONOPARED

Datos técnicos

Technical parameters / Paramètres techniques / Dados técnicos

Material Matière	AL. 6063T5	
Lamas por metro de altura Necessary slats per height meter / Nombre de lames au mètre / Lâminas por metro de altura	10	
Superficie de cobertura (mm) Surface coverage / Surface de couverture	100	
Eje mínimo de enrollamiento Ø (mm) Minimum rolling shaft / Axe minimal d'enroulement / Eixo mínimo de enrolamento	100	
Resistencia al viento (Clase) UNE - EN 13241 Wind resistance / Résistance au vent Resistência ao vento	5+ 2893 Pa	5 1050 Pa
Anchura ensayada Tested width / Largeur du tablier testée	4,00	7,00
Peso m² aprox. Weight per m2 / Poids m² approximatif	9,64 Kg / m²	



Resistencia al viento según UNE-EN 13241

Wind resistance according to UNE-EN 13241

Résistance au vent conformément à la norme UNE-EN 13241

Clase de Viento

- C1 : 300 Pa ≈ 80 km/h
- C2 : 450 Pa ≈ 98 km/h
- C3 : 700 Pa ≈ 122 km/h
- C4 : 1000 Pa ≈ 145 km/h
- C5 : Mayor a 1000 Pa

Ancho de paño (mm)

Shutter width
Largeur du tablier

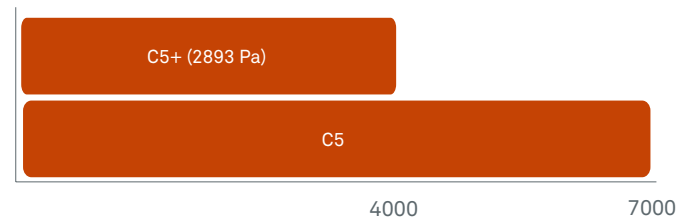

Lama

Slats / Lame / Lama

313150 AL V-100 MONOPARED



Material Matière	Aluminio 6063T5
Espesor aprox. (mm) Approx. thickness / Épaisseur approx / Grossura nominal	2.0
Peso m. lineal (g) Linear m. weight / Poids m. linéaire / Peso linear	964
Perímetro total (mm) Total perimeter / Périmètre total / Perímetro total	384

Remate

End slat / Lame finale/ Remate

313118 REMATE AL V-100

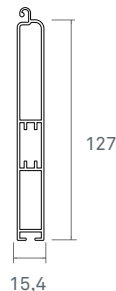

360026 GOMA REMATE

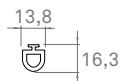

Material Matière	Aluminio 6063T5
Espesor aprox. (mm) Approx. thickness / Épaisseur approx / Grossura nominal	1.5
Peso m. lineal (g) Linear m. weight / Poids m. linéaire / Peso linear	1355
Perímetro total (mm) Total perimeter / Périmètre total / Perímetro total	662

Guía ensayada

Tested guides/ Coulisses testée.

308237 GUÍA AL V-100 EXTREME

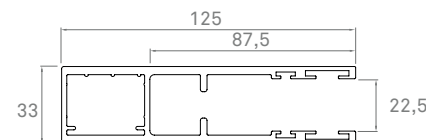

Material Matière	Aluminio 6063T5
Espesor aprox. (mm) Approx. thickness / Épaisseur approx / Grossura nominal	3.0
Peso m. lineal (g) Linear m. weight / Poids m. linéaire / Peso linear	2768
Perímetro total (mm) Total perimeter / Périmètre total / Perímetro total	730

Tapón compatible

Compatible side lock / Compatible embout latéra

160462 JGO. TAPÓN LATERAL V-100 EXTREME

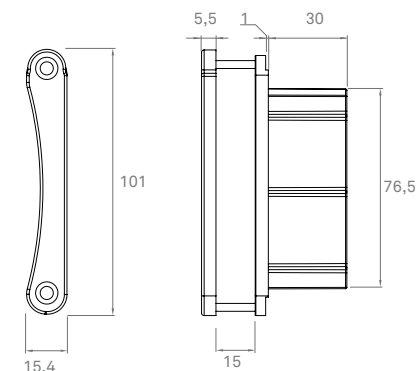

■ **Vista explosionada**
Componentes / Composants

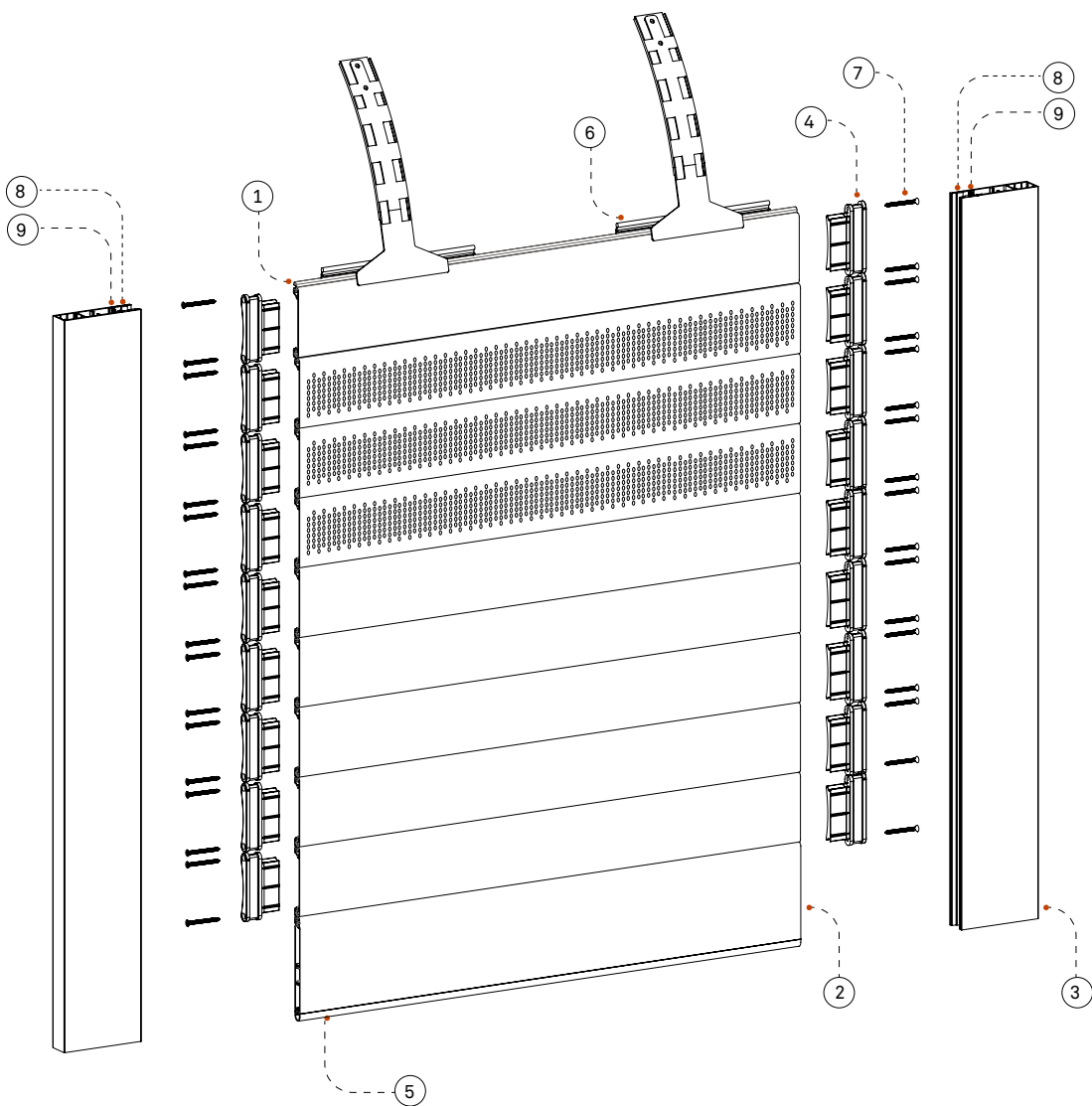

■ **Componentes**
Componentes / Composants

ID	CÓDIGO Code	ARTÍCULOS Articles
1	313150	LAMA / Slat /Lame
2	313118	REMATE / End slat / Lame finale
3	308237	GUIA ALV-100 EXTREME / Extreme guide / Coulisse extreme
4	160462	JGO. TAPÓN LATERAL EXTREME / Pair of end caps of slat / Jeu bouchon lame
5	360026	GOMA REMATE / End slat rubber / Joint lame finale
6	160344	TIRANTE FLEJE V - 100 / Spring / Attache
7	111916	TORNILLO 4,2 x 50mm / Screw 4,2 x 50 / Vis 4,2 x 50
8	360023	GOMA GUÍA DURO 6mm / Rubber guide / Joint Coulisse
9	311014	FELPUDO GUÍA 7,5 X 9 / Brush guide / Brusher Coulisse

■ **Versiones**

Versions

313168 MICROPERFORADA

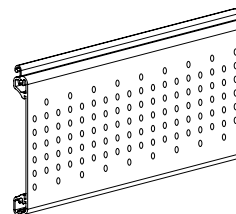

Peso lama perforada (g/m) Weight / Poids	874
Perforación Ø (mm) Perforation	3,5
Ventilación (m2/m) Ventilation	0,25

■ **Descuentos**

Discounts / Réductions / Descontos

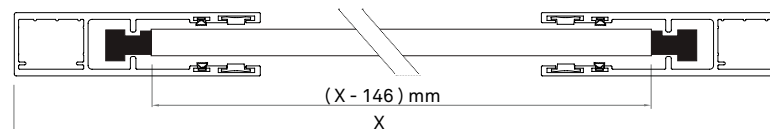

240023 VS-150 BLOCK60 EXTREME

FICHA DE SISTEMA / SYSTEM DATASHEET / FICHE TECHNIQUE DU SYSTÈME / FICHA DE DADOS DO SISTEMA

313002 LAMA AL VS-150 BLOCK 60 - DOBLEPARED

Datos técnicos

Technical parameters / Paramètres techniques / Dados técnicos

Material Matière	AL. 6063T5	
Lamas por metro de altura Necessary slats per height meter / Nombre de lames au mètre / Lâminas por metro de altura	13,7	
Superficie de cobertura (mm) Surface coverage / Surface de couverture	73	
Eje mínimo de enrollamiento Ø (mm) Minimum rolling shaft / Axe minimal d'enroulement / Eixo mínimo de enrolamento	70	
Resistencia al viento (Clase) UNE - EN 13241 Wind resistance / Résistance au vent Resistência ao vento	5+ 4422 Pa	2
Anchura ensayada Tested width / Largeur du tablier testée	3,00	6,50
Peso m ² aprox. Weight per m2 / Poids m ² approximatif	9,64 Kg / m ²	
Incremento peso + 30% (Lamas + Varillas unión) para motor Weight increased + 30% Augmentation poids + 30 %	3,08 Kg / m ²	



Resistencia al viento según UNE-EN 13241

Wind resistance according to UNE-EN 13241

Résistance au vent conformément à la norme UNE-EN 13241

Clase de Viento

- C1 : 300 Pa ≈ 80 km/h
- C2 : 450 Pa ≈ 98 km/h
- C3 : 700 Pa ≈ 122 km/h
- C4 : 1000 Pa ≈ 145 km/h
- C5 : Mayor a 1000 Pa

Ancho de paño (mm)

Shutter width
Largeur du tablier

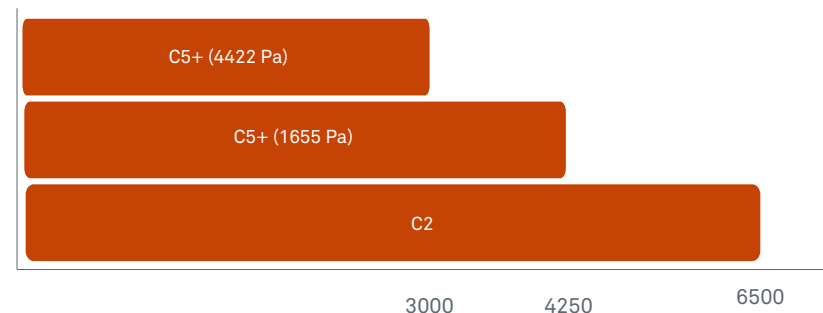

Lama

Slats / Lame / Lama

313002 LAMA DOBLE PARED



Varilla

Middle slat / Lame intermédiaire

313044 VARILLA UNIÓN



Remate

End slat / Lame finale

313028 REMATE

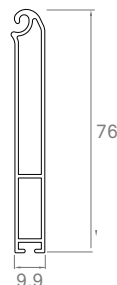

360004 GOMA REMATE

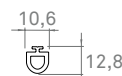

Guia ensayada

Tested guides / Coulisses testée

308196 GUIA AL EXTREME

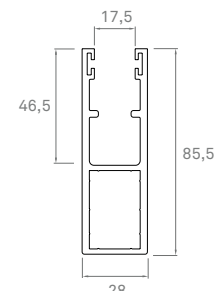

Tapón compatible

Compatible end cap / Bouchon compatible

160270 JGO.TAPÓN AL BLOCK - 60 EXTREME

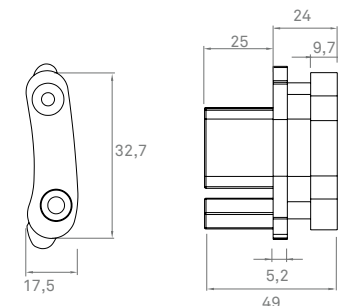

Material Matière	Aluminio 6063T5
Espesor aprox. (mm) Approx. thickness / Épaisseur approx / Grossura nominal	1,2
Peso m. lineal (g) Linear m. weight / Poids m. linéaire / Peso linear	562
Perímetro total (mm) Total perimeter / Périmètre total / Périmetro total	300

Material Matière	Aluminio 6063T5
Espesor aprox. (mm) Approx. thickness / Épaisseur approx / Grossura nominal	2,0
Peso m. lineal (g) Linear m. weight / Poids m. linéaire / Peso linear	197
Perímetro total (mm) Total perimeter / Périmètre total / Périmetro total	84

Material Matière	Aluminio 6063T5
Espesor aprox. (mm) Approx. thickness / Épaisseur approx / Grossura nominal	1.2
Peso m. lineal (g) Linear m. weight / Poids m. linéaire / Peso linear	645
Perímetro total (mm) Total perimeter / Périmètre total / Périmetro total	354

Material Matière	Aluminio 6063T5
Espesor aprox. (mm) Approx. thickness / Épaisseur approx / Grossura nominal	3.0
Peso m. lineal (g) Linear m. weight / Poids m. linéaire / Peso linear	1790
Perímetro total (mm) Total perimeter / Périmètre total / Périmetro total	487

■ **Vista explosionada**
Componentes / Composants

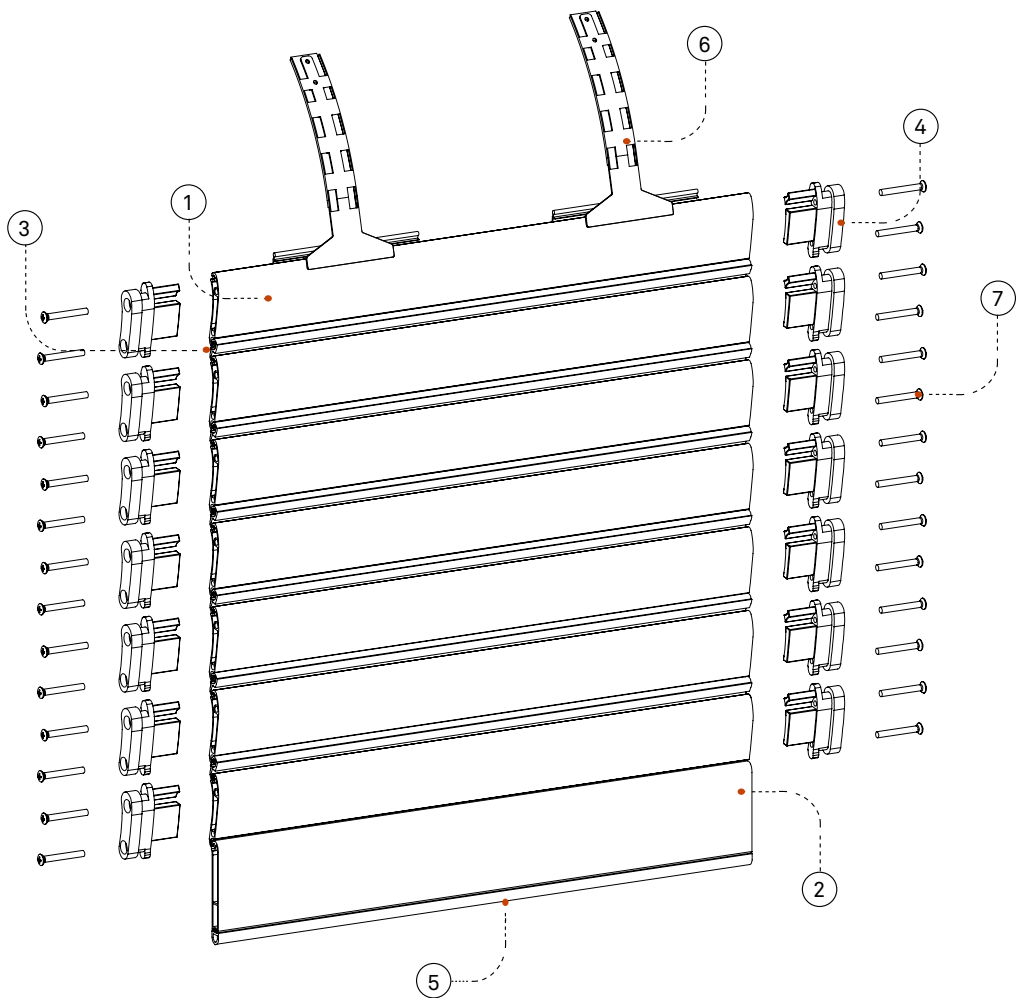

■ **Componentes**
Componentes / Composants

ID	CÓDIGO Code / Código	ARTÍCULOS Articles
1	313002	LAMA DOBLEPARED / Double-skin slat /Lame Double-Paroi
2	313028	REMATE / End slat / Lame finale
3	313044	VARILLA DE UNIÓN / Middle slat / Lame intermédiaire
4	160270	JGO. TAPÓN LAMA / Pair of end caps / Jeu bouchon
5	360004	GOMA REMATE / End slat rubber / Joint lame finale
6	160055	TIRANTE ACERO REVESTIDO / Iron Spring / Attache métallique
7	111597	TORNILLO 5,5 x 38 mm / Screw / Vis

■ **Descuentos**
Discounts / Réductions / Descontos

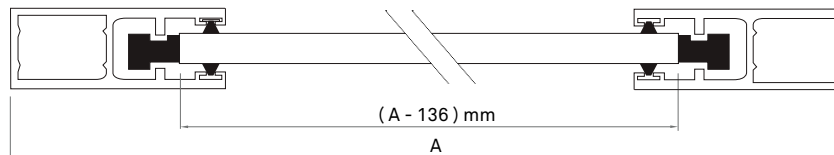

11nan
PREMIOS
arquitectura y construcción
PRODUCTO GANADOR

240023 VS-150 BLOCK 60 EXTREME

PERSAX S27

240034 VS-300 BLOCK95 EXTREME

FICHA DE SISTEMA / SYSTEM DATASHEET / FICHE TECHNIQUE DU SYSTÈME / FICHA DE DADOS DO SISTEMA

313192 LAMA AL VS-300 BLOCK 95

Datos técnicos

Technical parameters / Paramètres techniques / Dados técnicos

Material Matière	AL. 6063T5	
Lamas por metro de altura Necessary slats per height meter / Nombre de lames au mètre / Lâminas por metro de altura	9	
Superficie de cobertura (mm) Surface coverage / Surface de couverture	101	
Eje mínimo de enrollamiento Ø (mm) Minimum rolling shaft / Axe minimal d'enroulement / Eixo mínimo de enrolamento	100	
Resistencia al viento (Clase) UNE - EN 13241 Wind resistance / Résistance au vent Resistência ao vento	5+ 2893 Pa	5 + 1231 Pa
Anchura ensayada Tested width / Largeur du tablier testée	5,00	8,00
Peso m ² aprox. Weight per m2 / Poids m ² approximatif	9,64 Kg / m ²	
Incremento peso + 30% (Lamas + Varillas unión) para motor Weight increased + 30% Augmentation poids + 30 %	3,08 Kg / m ²	



Resistencia al viento según UNE-EN 13241

Wind resistance according to UNE-EN 13241

Résistance au vent conformément à la norme UNE-EN 13241

Clase de Viento

- C1 : 300 Pa ≈ 80 km/h
- C2 : 450 Pa ≈ 98 km/h
- C3 : 700 Pa ≈ 122 km/h
- C4 : 1000 Pa ≈ 145 km/h
- C5 : Mayor a 1000 Pa

Ancho de paño (mm)

Shutter width
Largeur du tablier

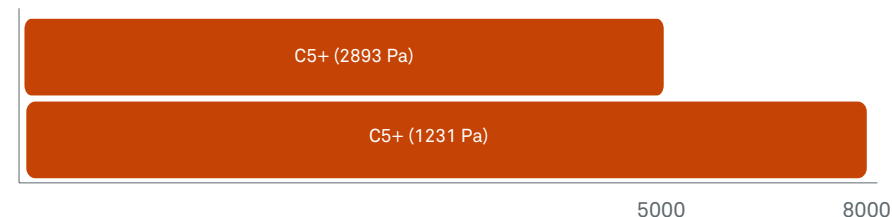

Lama

Slats / Lame / Lama

313192 LAMA DOBLEPARED

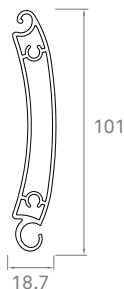

Varilla

Middle slat / Lame intermédiaire

313196 VARILLA UNIÓN



Remate

End slat / Lame finale

313030 REMATE

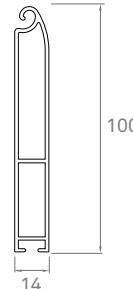

360026 GOMA REMATE



Guía ensayada

Tested guides / Coulisses testée

308235 GUIA AL EXTREME VS-300

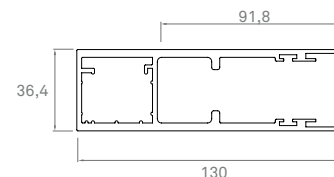

Tapón compatible

Compatible end cap / Bouchon compatible

160356 JGO.TAPÓN AL VS-300 EXTREME

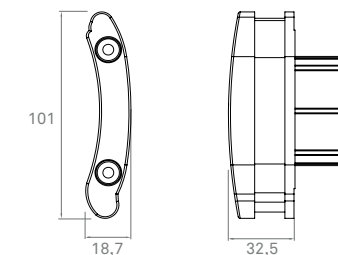

Material Matière	Aluminio 6063T5
Espesor aprox. (mm) Approx. thickness / Épaisseur approx / Grossura nominal	1,5
Peso m. lineal (g) Linear m. weight / Poids m. linéaire / Peso linear	1077
Perímetro total (mm) Total perimeter / Périmètre total / Périmetro total	513

Material Matière	Aluminio 6063T5
Espesor aprox. (mm) Approx. thickness / Épaisseur approx / Grossura nominal	2,0
Peso m. lineal (g) Linear m. weight / Poids m. linéaire / Peso linear	384
Perímetro total (mm) Total perimeter / Périmètre total / Périmetro total	116

Material Matière	Aluminio 6063T5
Espesor aprox. (mm) Approx. thickness / Épaisseur approx / Grossura nominal	1,5
Peso m. lineal (g) Linear m. weight / Poids m. linéaire / Peso linear	1007
Perímetro total (mm) Total perimeter / Périmètre total / Périmetro total	487

Material Matière	Aluminio 6063T5
Espesor aprox. (mm) Approx. thickness / Épaisseur approx / Grossura nominal	4,0
Peso m. lineal (g) Linear m. weight / Poids m. linéaire / Peso linear	2955
Perímetro total (mm) Total perimeter / Périmètre total / Périmetro total	774

■ **Vista explosionada**
Componentes / Composants

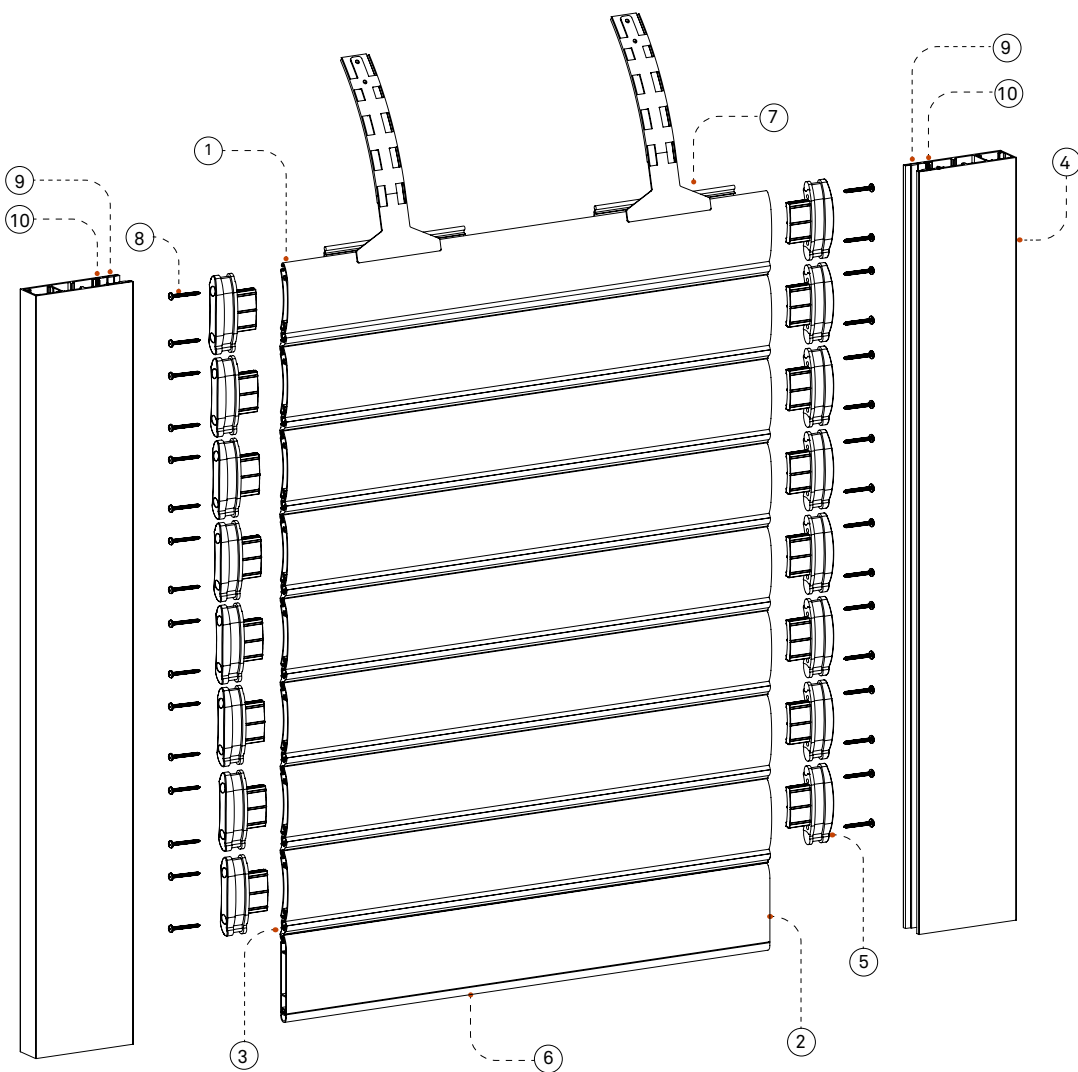

■ **Componentes**
Componentes / Composants

ID	CÓDIGO Code	ARTÍCULOS Articles
1	313192	LAMA / Slat /Lame
2	313030	REMATE / End slat / Lame finale
3	313196	VARILLA DE UNIÓN / Middle slat / Lame finale
4	308235	GUÍA AL EXTREME VS-300/ Extreme guide / Extreme Coulisse
5	160454	JGO. TAPÓN LATERAL EXTREME / Pair of end caps of slat / Jeu bouchon lame
6	360006	GOMA REMATE / End slat rubber / Joint lame finale
7	160349	TIRANTE FLEJE VS - 300/ Spring / Attache
8	111918	TORNILLO 5.5 X 60 DIN 7981 / Screw 5,5 x 60 DIN 7981 / Vis 5,5 x 60 DIN 7981
9	360021	GOMA GUIA AUTOBLOC. BLANDO 4MM / Rubber guide / Joint Coulisse
10	311014	FELPUDO 7.5 X 9 / Brush guide / Brusher Coulisse

■ **Descuentos**
Discounts / Réductions / Descontos

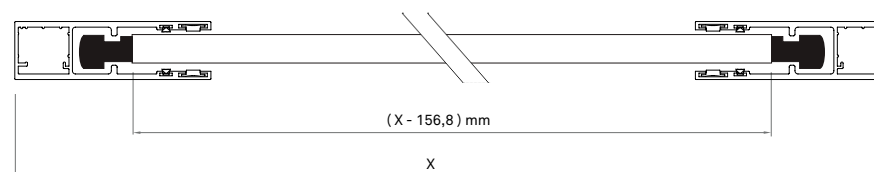

CUADRANTE CAPACIDAD POR MODELO DE CAJÓN

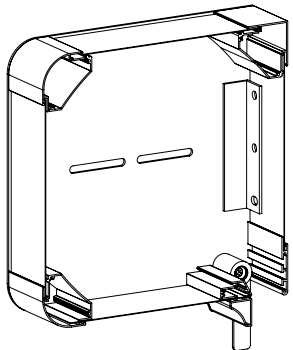
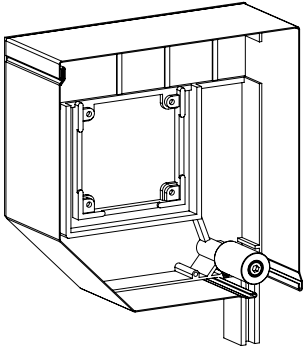
MODELO CAJÓN	TAMAÑOS	EJE	EXTRUSIÓN								EXTREME				PERFILADO
			VS-150	VS-300	VS-350	SEGUR EC-60	V-77	V-80	ECOSEGUR 100	V-100	SEGUR EC-60	V-100	VS-150	VS-300	PF-77
 EXBOX	300	Ø 70	1,80	-	-	2,10	1,55	-	-	-	2,10	-	1,80	-	2,20
		Ø 100	1,60	-	-	1,65	1,35	-	-	-	1,65	-	1,60	-	2,00
		Ø 133	1,25	-	-	-	-	-	1,60	-	-	-	1,25	-	-
	350	Ø 70	3,60	-	-	4,35	3,90	-	-	-	4,35	-	3,60	-	3,10
		Ø 100	3,60	-	-	3,50	2,60	2,35	-	-	3,50	-	3,60	-	2,20
		Ø 133	3,30	2,40	1,75	-	2,40	1,95	1,80	2,95	-	2,55	3,30	2,40	-
		Ø 220	-	-	-	-	-	-	-	1,35	-	1,35	-	-	-
	400	Ø 70	4,40	-	-	4,40	4,20	-	-	-	4,40	-	4,40	-	3,60
		Ø 100	4,40	-	-	4,40	3,80	3,60	-	-	4,40	-	4,40	-	3,40
		Ø 133	4,40	3,60	2,50	-	3,65	3,45	3,40	4,10	-	3,60	4,40	3,60	-
		Ø 220	-	-	-	-	2,20	2,25	2,40	2,90	-	2,40	-	-	1,80
		Ø 240	-	-	-	-	2,05	2,00	-	2,30	-	2,00	-	-	-
450	Ø 100	4,45	-	-	4,45	4,50	4,45	-	-	4,45	-	4,45	-	4,40	
	Ø 133	4,45	5,35	2,95	4,45	4,50	4,45	4,00	4,45	4,45	5,05	4,45	5,35	-	
	Ø 220	-	-	-	-	3,50	3,50	3,60	3,95	-	3,25	-	-	3,00	
	Ø 240	-	-	-	-	3,10	3,10	-	3,95	-	3,05	-	-	-	
 ALUMINIO PERFILADO	300	Ø 70	3,40	-	-	3,70	2,55	-	-	-	3,70	-	3,40	-	2,00
		Ø 100	3,40	-	-	3,30	2,55	2,10	-	-	3,30	-	3,40	-	1,80
		Ø 133	2,90	2,10	1,50	-	2,10	1,90	2,00	2,70	-	2,30	2,90	2,10	-
		Ø 220	-	-	-	-	-	-	-	-	-	-	-	-	-
	350	Ø 70	4,20	-	-	4,35	3,90	-	-	-	4,35	-	4,20	-	-
		Ø 100	4,20	-	-	4,35	3,75	3,40	-	-	4,35	-	4,20	-	3,20
		Ø 133	4,00	3,30	2,35	-	3,40	3,00	3,20	4,05	-	3,35	4,00	3,30	-
		Ø 220	-	-	-	-	2,00	1,80	2,20	2,45	-	2,15	-	-	1,60
		Ø 240	-	-	-	-	1,60	1,80	-	2,05	-	1,65	-	-	-
	400	Ø 100	4,25	-	-	4,40	4,45	4,40	-	-	4,40	-	4,25	-	4,40
		Ø 133	4,25	4,50	2,90	4,40	4,45	4,40	4,00	4,40	4,40	5,00	4,25	4,50	-
		Ø 220	-	-	-	-	3,45	3,45	3,40	4,20	-	3,20	-	-	3,00
Ø 240		-	-	-	-	3,05	3,05	-	4,20	-	3,00	-	-	-	

Guías y compatibilidades

SYSTEMS GLOSSARY
GLOSSAIRE DES SYSTÈMES



GUÍAS EXTRUSIÓN EXTREME / GUIDES / COULISSES

■ **308196** GUÍA AL EXTREME
EXTREME ALU GUIDE
COULISSE ALU EXTRÊME

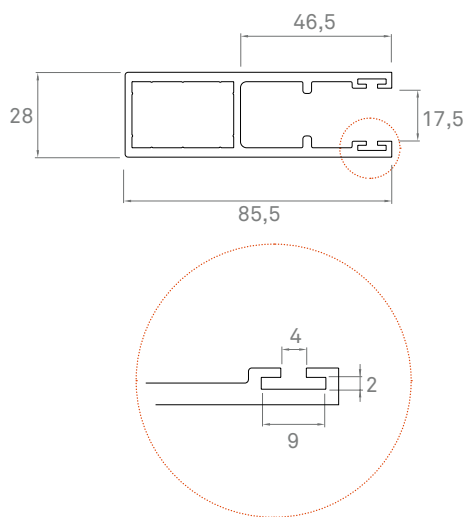

Material Matière	Aluminio 6063T5
Espesor aprox. (mm) Approx. thickness / Épaisseur approx	3.0
Peso m. lineal (g) Linear m. weight / Poids m.linéaire	1790
Perímetro total (mm) Total perimeter / Périmètrétotal	487
Lamas Compatibles Compatible slats / Lames compatibles	EC-60 VS-150



■ **308237** GUÍA AL V-100 EXTREME
V-100 EXTREME ALU GUIDE
COULISSE ALU V-100 EXTRÊME

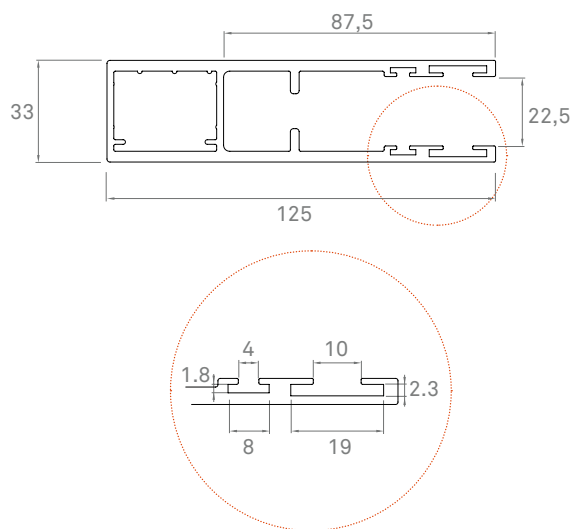

Material Matière	Aluminio 6063T5
Espesor aprox. (mm) Approx. thickness / Épaisseur approx	13.0
Peso m. lineal (g) Linear m. weight / Poids m.linéaire	2768
Perímetro total (mm) Total perimeter / Périmètrétotal	730
Lamas Compatibles Compatible slats / Lames compatibles	V-100

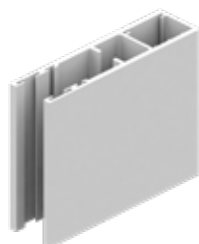

■ **308235** GUÍA AL EXTREME VS-300
VS-300 EXTREME ALU GUIDE
COULISSE ALU VS-300 EXTRÊME

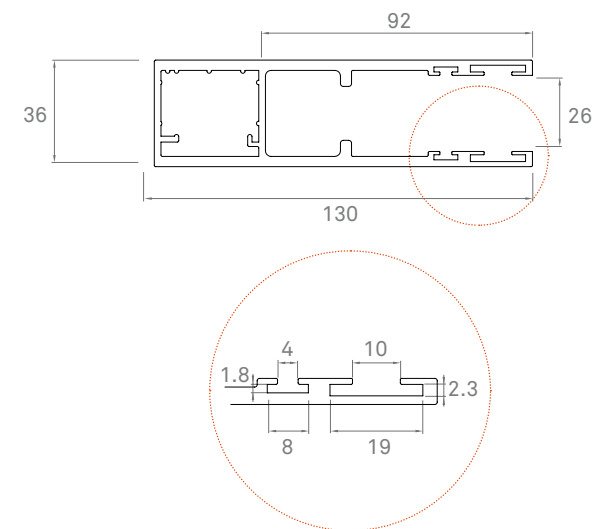

Material Matière	Aluminio 6063T5
Espesor aprox. (mm) Approx. thickness / Épaisseur approx	4.0
Peso m. lineal (g) Linear m. weight / Poids m.linéaire	2955
Perímetro total (mm) Total perimeter / Périmètrétotal	774
Lamas Compatibles Compatible slats / Lames compatibles	VS-300

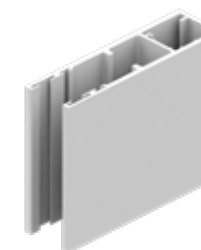

GUÍAS EXTRUSIÓN / GUIDES / COULISSES

■ **308202** GUÍA AL GS -100
GS-100 ALU GUIDE
COULISSE ALU GS-100

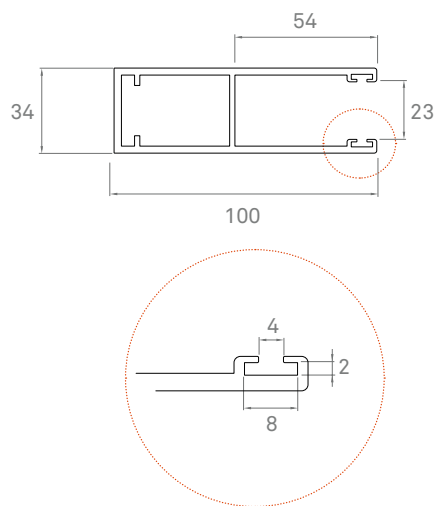

■ **308205** GUÍA AL GS-130
GS-130 ALU GUIDE
COULISSE ALU GS-130

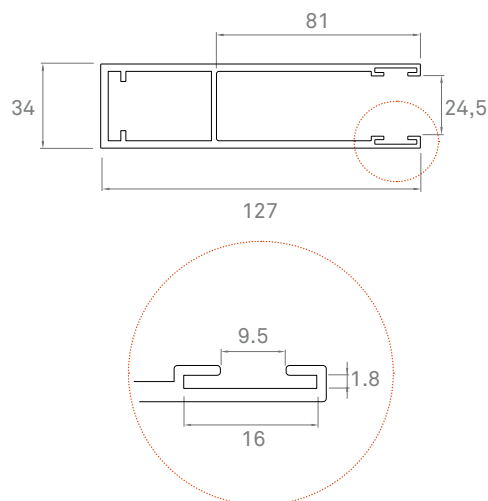

■ **308211** GUÍA AL GEM - 65
GEM-65 ALU GUIDE
COULISSE ALU GEM-65

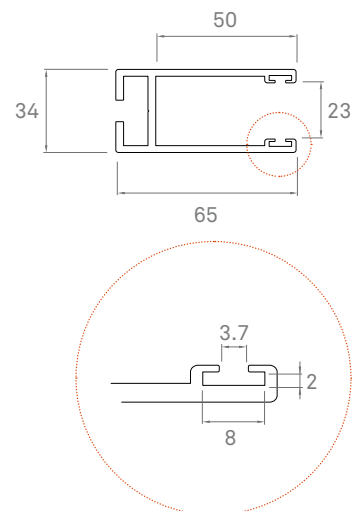

■ **308213** GUÍA AL GEM - 75
GEM-75 ALU GUIDE
COULISSE ALU GEM-75

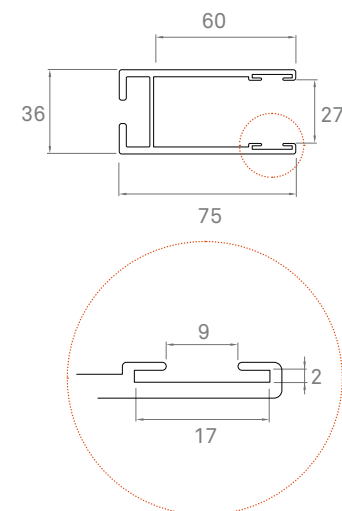

Material Matière	Aluminio 6063T5
Espesor aprox. (mm) Approx. thickness / Épaisseur approx	2.8
Peso m. lineal (g) Linear m. weight / Poids m.linéaire	1978
Perímetro total (mm) Total perimeter / Périmètretotal	568
Lamas Compatibles Compatible slats Lames compatibles	V-77 PF V - 80 ECOSEGUR 100 V - 100 V - 77

Material Matière	Aluminio 6063T5
Espesor aprox. (mm) Approx. thickness / Épaisseur approx	3.0
Peso m. lineal (g) Linear m. weight / Poids m.linéaire	2439
Perímetro total (mm) Total perimeter / Périmètretotal	685
Lamas Compatibles Compatible slats Lames compatibles	V - 100 V - 77 V - 80 VS - 300 VS - 350 V - 77 PF

Material Matière	Aluminio 6063T5
Espesor aprox. (mm) Approx. thickness / Épaisseur approx	2.8
Peso m. lineal (g) Linear m. weight / Poids m.linéaire	1398
Perímetro total (mm) Total perimeter / Périmètretotal	393
Lamas Compatibles Compatible slats Lames compatibles	V-77 PF V-80 ECOSEGUR 100 V-100 V-77

Material Matière	Aluminio 6063T5
Espesor aprox. (mm) Approx. thickness / Épaisseur approx	3.0
Peso m. lineal (g) Linear m. weight / Poids m.linéaire	1475
Perímetro total (mm) Total perimeter / Périmètretotal	450
Lamas Compatibles Compatible slats Lames compatibles	VS - 300 VS - 350

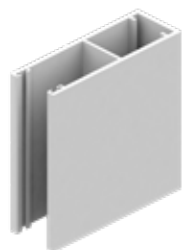

GUÍAS EXTRUSIÓN / GUIDES / COULISSES

■ **308039** GUIA AL HC-66 / GA-66
HC-66/GA-66 ALU GUIDE
COULISSE ALU HC-66/GA-66

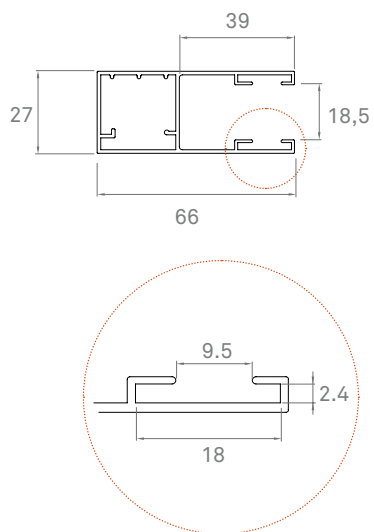

Material Matière	Aluminio 6063T5
Espesor aprox. (mm) Approx. thickness / Épaisseur approx	1.2
Peso m. lineal (g) Linear m. weight / Poids m.linéaire	712
Perímetro total (mm) Total perimeter / Périmètrtotal	445
Lamas Compatibles Compatible slats Lames compatibles	VS - 150 EC - 60



■ **308033** GUIA AL H-76 / GA-75
H-76/GA-75 ALU GUIDE
COULISSE ALU H-76/GA-75

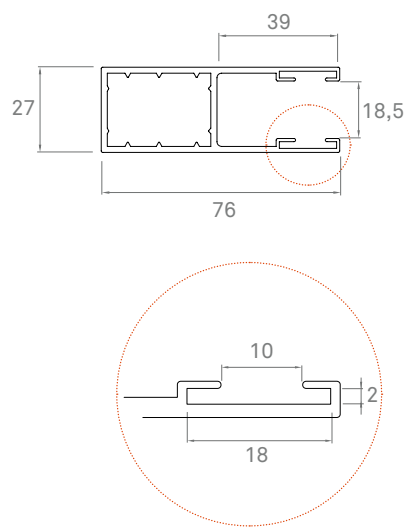

Material Matière	Aluminio 6063T5
Espesor aprox. (mm) Approx. thickness / Épaisseur approx	1.5
Peso m. lineal (g) Linear m. weight / Poids m.linéaire	928
Perímetro total (mm) Total perimeter / Périmètrtotal	475
Lamas Compatibles Compatible slats Lames compatibles	EC - 60 V - 10 VS - 150



■ **308217** GUIA AL GSO - 105
GSO-105 ALU GUIDE
COULISSE ALU GSO-105

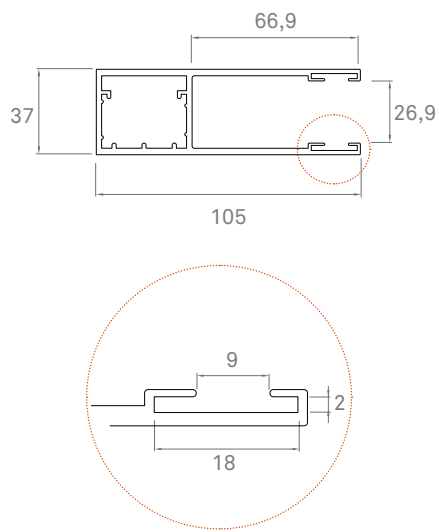

Material Matière	Aluminio 6063T5
Espesor aprox. (mm) Approx. thickness / Épaisseur approx	2.8
Peso m. lineal (g) Linear m. weight / Poids m.linéaire	2019
Perímetro total (mm) Total perimeter / Périmètrtotal	637
Lamas Compatibles Compatible slats Lames compatibles	VS - 300 VS - 350



■ **308209** GUIA AL GA - 95
GA-95 ALU GUIDE
COULISSE ALU GA-95

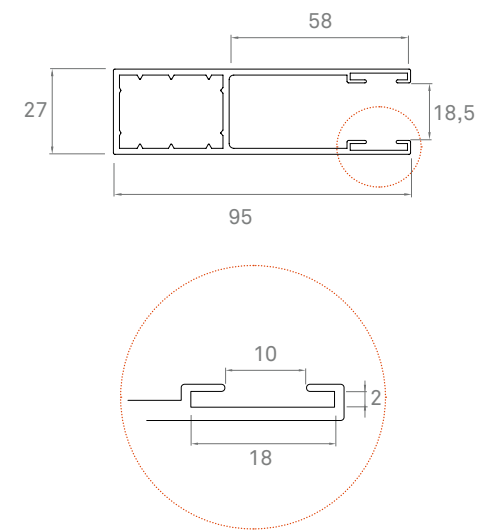

Material Matière	Aluminio 6063T5
Espesor aprox. (mm) Approx. thickness / Épaisseur approx	2.0
Peso m. lineal (g) Linear m. weight / Poids m.linéaire	1302
Perímetro total (mm) Total perimeter / Périmètrtotal	532
Lamas Compatibles Compatible slats Lames compatibles	EC - 60 VS - 150



GUÍAS PREMARCOS / GUIDES / COULISSES

■ **308221** GUÍA AL PREMARCO 105 X 80
 ALU FRAME GUIDE 105 X 80
 COULISSE ALU CADRE 105 X 80

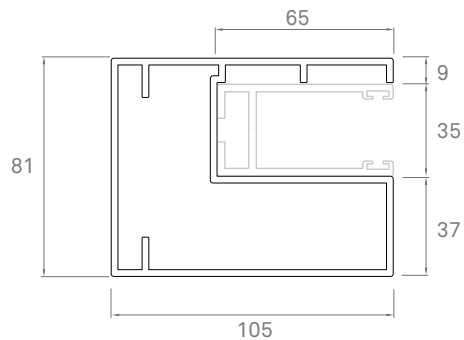

Guías compatibles:

308211 GUIA AL GEM - 65

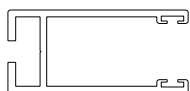

308213 GUIA AL GEM - 75

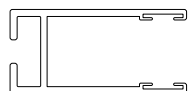

Material Matière	Aluminio 6063T5
Espesor aprox. (mm) Approx. thickness / Épaisseur approx	2.5
Peso m. lineal (g) Linear m. weight / Poids m.linéaire	3147
Perímetro total (mm) Total perimeter / Périmèretotal	930
Lamas Compatibles Compatible slats Lames compatibles	V-77 PF
	V-80
	ECOSEGUR 100
	V-100
	V-77

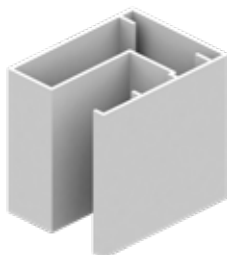

■ **308223** GUÍA AL PREMARCO 80 X 80
 ALU FRAME GUIDE 80 X 80
 COULISSE ALU CADRE 80 X 80

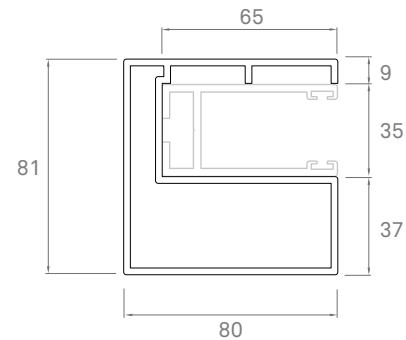

Guías compatibles:

308211 GUIA AL GEM - 65

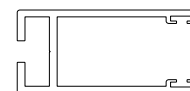

308213 GUIA AL GEM - 75

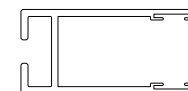

Material Matière	Aluminio 6063T5
Espesor aprox. (mm) Approx. thickness / Épaisseur approx	2.5
Peso m. lineal (g) Linear m. weight / Poids m.linéaire	2642
Perímetro total (mm) Total perimeter / Périmèretotal	781
Lamas Compatibles Compatible slats Lames compatibles	V-77 PF
	V-80
	ECOSEGUR 100
	V-100
	V-77



GUÍAS A OBRA GUIDES / COULISSES

■ 308207 GUÍA AL GSR - 66
GSR-66 ALU GUIDE
COULISSE ALU GSR-66

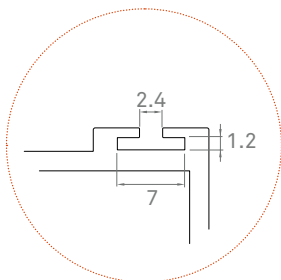
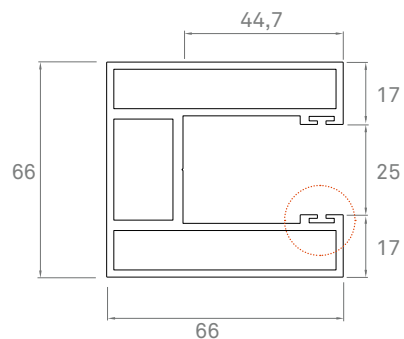

Material Matière	Aluminio 6063T5
Espesor aprox. (mm) Approx. thickness / Épaisseur approx	2.0
Peso m. lineal (g) Linear m. weight / Poids m.linéaire	2227
Perímetro total (mm) Total perimeter / Périmètretotal	758
Lamas Compatibles Compatible slats Lames compatibles	V-77 PF
	V-80
	ECOSEGUR 100
	V-100
	V-77

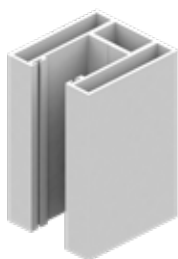

■ 308219 GUÍA AL PREMARCO 120X80 MM DOBLE TAQUILLA
GUIDE TO PRE-FRAME 120 X 80 MM DOUBLE LOCKER
GUIDE POUR LE PRÉCADRE 120 X 80 MM DOUBLE CASIER

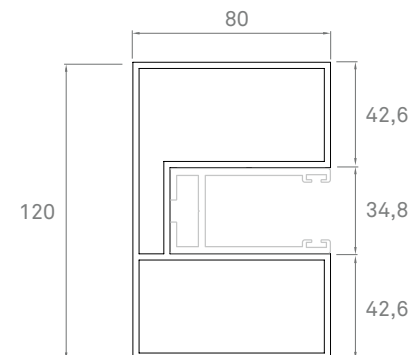

Guías compatibles:

308211 GUIA AL GEM - 65

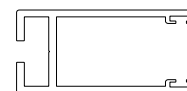

Material Matière	Aluminio 6063T5
Espesor aprox. (mm) Approx. thickness / Épaisseur approx	2.5
Peso m. lineal (g) Linear m. weight / Poids m.linéaire	3578
Perímetro total (mm) Total perimeter / Périmètretotal	1055
Lamas Compatibles Compatible slats Lames compatibles	V-77 PF
	V-80
	ECOSEGUR 100
	V-100
	V-77

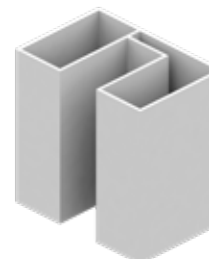

GUÍAS A OBRA GUIDES / COULISSES

■ 308121 GUÍA AL SE - 55
SE-55 ALU GUIDE
COULISSE ALU SE-55

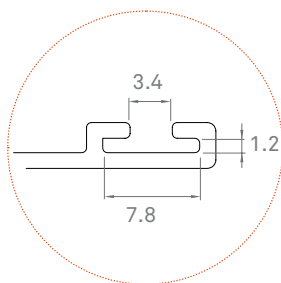
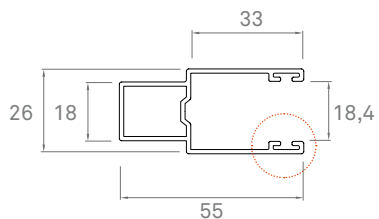

Material Matière	Aluminio 6063T5
Espesor aprox. (mm) Approx. thickness /Épaisseur approx	1.3
Peso m. lineal (g) Linear m. weight / Poids m.linéaire	591
Perímetro total (mm) Total perimeter / Périmètretotal	332
Lamas Compatibles Compatible slats Lames compatibles	V-80 ECOSEGUR 100 V-100



■ 308225 GUÍA AL VT - 18
VT-18 ALU GUIDE
COULISSE ALU VT-18

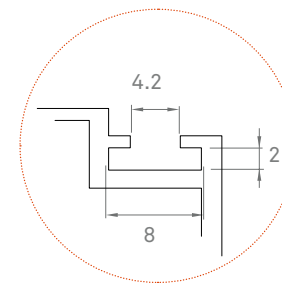
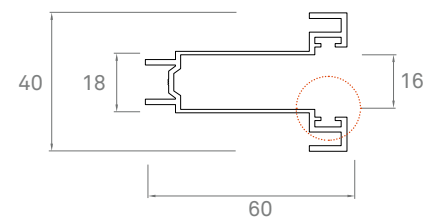

Material Matière	Aluminio 6063T5
Espesor aprox. (mm) Approx. thickness /Épaisseur approx	1.3
Peso m. lineal (g) Linear m. weight / Poids m.linéaire	696
Perímetro total (mm) Total perimeter / Périmètretotal	388
Lamas Compatibles Compatible slats Lames compatibles	ECOSEGUR 100 V-100



GOMAS Y FELPUDOS/RUBBERS/JOINTS

■ **360023** GOMA GUÍA DURO 6MM
GUIDE RUBBER HARD 6MM
JOINT COULISSE DUR 6MM

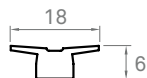

■ **360007** GOMA GUÍA H-100 PUERTA
RUBBER GUIDE H-100 DOOR
JOINT COULISSE H-100 PORTE

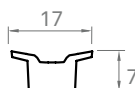

■ **360003** GOMA GUÍA PUERTA 17.50X4.50 GRIS
DOOR GUIDE RUBBER 17.50X4.50 GREY
JOINT COULISSE PORTE 17.50X4.50 GRIS

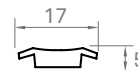

■ **360021** GOMA GUÍA AUTOBLOC. BLANDO 4MM
SELFBLOCK. GUIDE RUBBER SOFT 4MM
JOINT COULISSE AUTOBLOC MOU 4MM



■ **311065** GOMA GUÍA COMPACTO BLOCK45/39
GUIDE RUBBER BLOCK45/39
JOINT COULISSE BLOCK 45/39



■ **360022** GOMA GUÍA DURO 4MM
GUIDE RUBBER HARD 4MM
JOINT COULISSE DUR 4MM

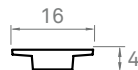

■ **360018** GOMA JUNTA CON ALETA PARA GUIA
RUBBER GUIDE
JOINT COULISSE AILE



■ **360024** FELPUDO 17X8 NEGRO
GUIDE BRUSH 7X6
BROSSE 7X6 COULISSE

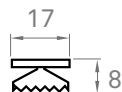



















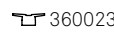
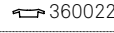













■ **311029** FELPUDO 7X6 GUÍA COMP
BRUSH 17X8 BLACK
BROSSE 17X8 NOIR



COMPATIBILIDADES/ COMPATIBILITIES/ COMPATIBILITÉS

GOMAS, FELPUDOS Y COMPATIBILIDADES

Guía\Lama	Secgur EC-60	V-77 Monopared	V-77 PF	V-80	V-100 Monopared	Ecosegur 100	VS-150 Block 60	VS-300 Block 95	VS-350 Block 110	Secgur EC-60 Extreme	VS-150 Block 60 Extreme	V-100 Extreme	VS-300 Block 95 Extreme
308196 AL EXTREME	-	-	-	-	-	-	-	-	-	 311065	 311065	-	-
308209 AL GA-95	 360003	-	-	-	-	-	-	-	-	-	-	-	-
308202 AL GS-100	-	 360018	 311029	 360018	 360018	 360018	 360021	-	-	-	-	-	-
308205 AL GS-130	-	 360022	 360022	 360023  360022	 360023	-	-	-	-	-	-	-	-
308217 AL GS0-105	-	-	-	-	-	-	-	 360021	-	-	-	-	-
308039 AL HC-66	 360003	-	-	-	-	-	 360003	-	-	-	-	-	-
308211 AL GEM-65	-	 360018	 311029	 360018	 360018	 360018	-	-	-	-	-	-	-
308213 AL GEM-75	-	-	-	-	-	-	-	 360021	 360021	-	-	-	-
308207 AL GSR-66	-	 360018	 311029	 311029  360018	 360018	 360018	-	-	-	-	-	-	-
308121 AL SE-55	-	-	-	-	-	-	-	-	-	-	-	-	-
308225 AL VT-18	-	-	-	-	-	-	-	-	-	-	-	-	-
308237 AL V-100 EXTREME	-	-	-	-	-	-	-	-	-	-	-	 360022  311029	-
308235 AL VS-300 EXTREME	-	-	-	-	-	-	-	-	-	-	-	-	 360021  311029

Glosario de Sistemas

SYSTEMS GLOSSARY
GLOSSAIRE DES SYSTÈMES



SISTEMA CON MOTOR TUBULAR

SYSTEM WITH TUBULAR MOTOR / SYSTÈME AVEC MOTOR TUBULAIRE

Ejemplo de montaje de una puerta enrollable con motor tubular en cajón de aluminio y paracaídas (5). / Example of a rolling door assembly with tubular motor in aluminium box and parachutes (5). / Exemple de montage d'une porte enrollable avec moteur tubulaire, coffre en aluminium et parachutes (5).

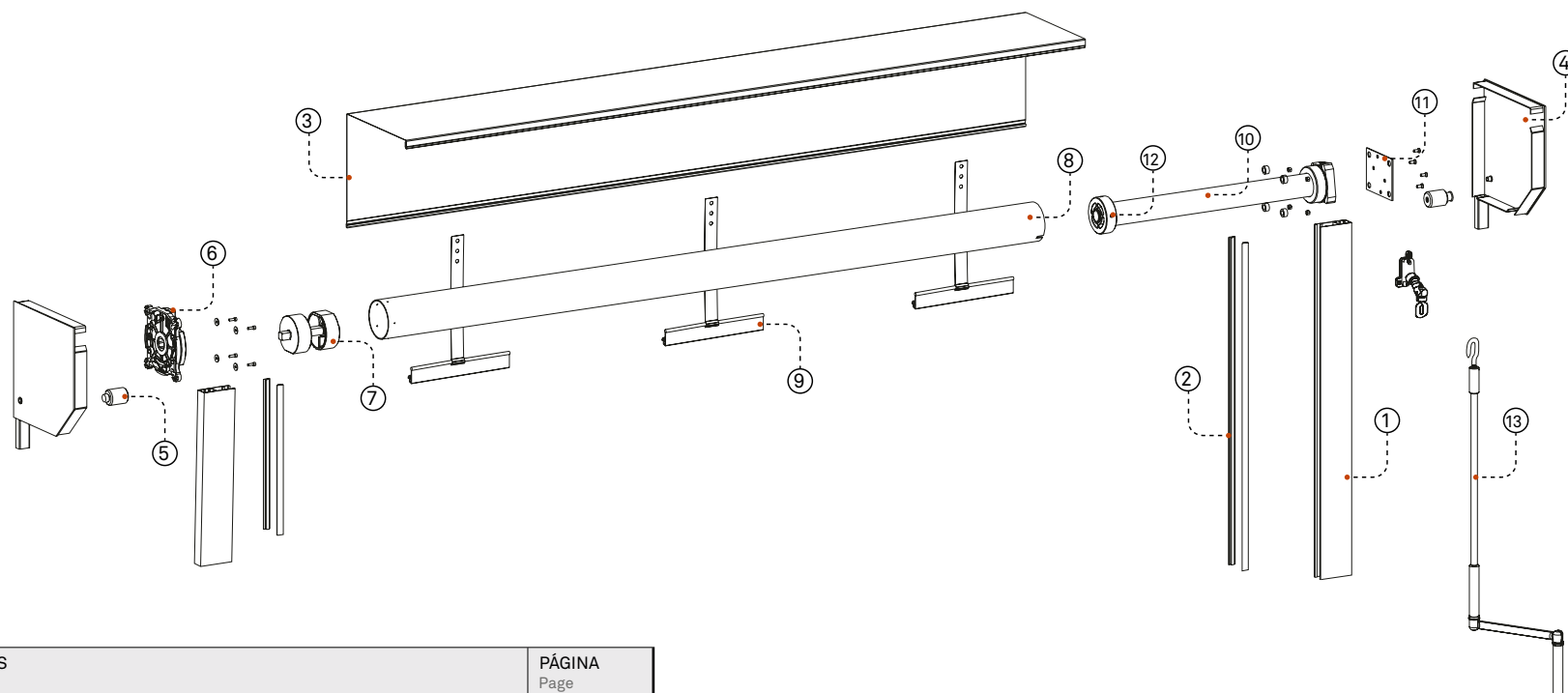

ID	ARTÍCULOS Articles	PÁGINA Page
1	Guia / Guide / Coulisse	64
2	Goma / Rubber / Joint	67
3	Cajón / Box / Coffre	69
4	Lateral / End Cap / Console	69
5	Rodillo / Roller / Roulette	73
6	Paracaídas / Parachutes / Parachutes	74
7	Contera / Adjustable Cap / Embout Axe	75
8	Eje / Shaft / Axe	76
9	Tirantes / Springs / Attaches	77
10	Motor Tubular / Tubular Motor / Moteur Tubulaire	78
11	Soporte Motor / Motor Bracket / Support Moteur	82
12	Corona - Rueda / Ring - Wheel / Couronne - Roue	83
13	Snodo - Manivela / Gear mechanism-Hand crank / Genouillère-Manivèle	84

SISTEMA CON MOTOR CENTRO-EJE

SYSTEM WITH CENTRAL MOTOR / SYSTÈME AVEC MOTOR CENTRAL

Ejemplo de montaje de una puerta enrollable con motor centro-eje en soportes escuadra. / Example of a rolling door assembly with central motor and steel supports. / Exemple de montage d'une porte enrollable avec moteur central et supports équerre.

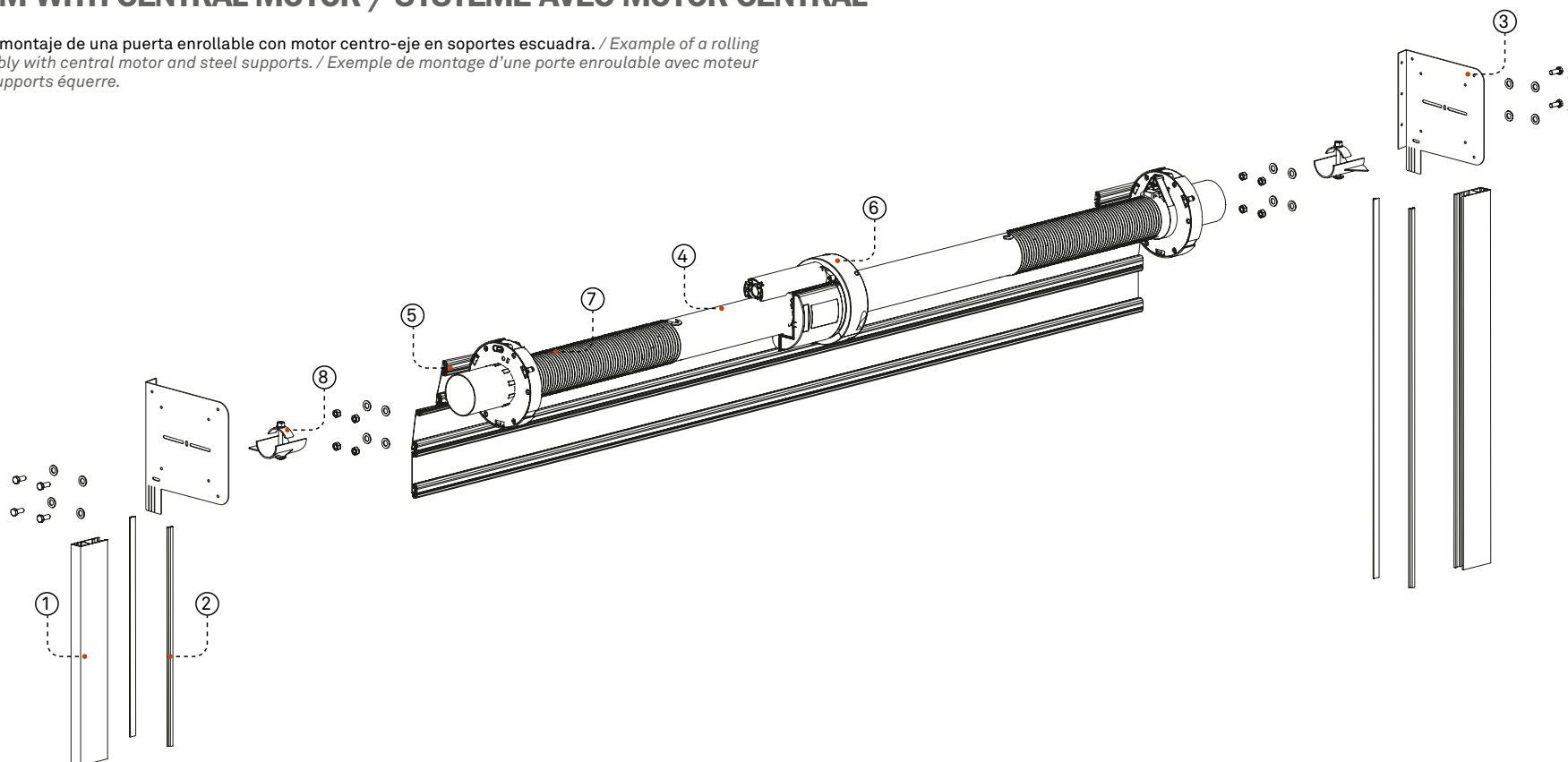

ID	ARTÍCULOS Articles	PÁGINA Page
1	Guía / Guide / Coulisse	64
2	Goma / Rubber / Joint	67
3	Soporte Escuadra / Steel Support / Support Équerre	73
4	Eje / Shaft / Axe	76
5	Tirantes (de lama) / Spring (of slat) / Attache (de lame)	77
6	Motor Central / Central Motor / Moteur Central	80
7	Muelles / Springs / Ressorts	80
8	Soporte Eje / Shaft Bracket / Support Axe	82

SISTEMA CON MOTOR LATERAL

SYSTEM WITH SIDE MOTOR / SYSTÈME AVEC MOTOR LATÉRAL

Ejemplo de montaje de una puerta enrollable con motor lateral en soportes escuadra. / Example of a rolling door assembly with side motor and supports. / Exemple de montage d'une porte enrollable avec moteur latéral et supports équerre.

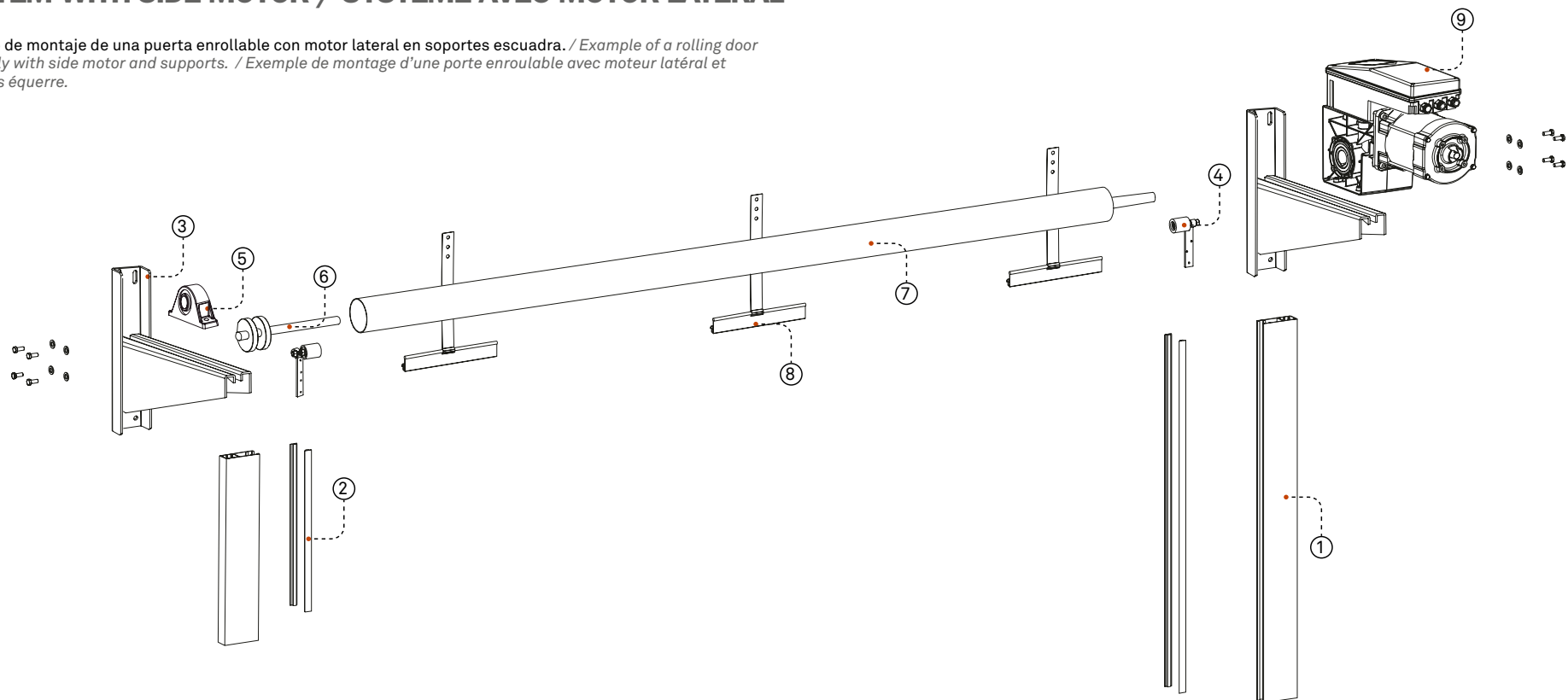

ID	ARTÍCULOS Articles	PÁGINA Page
1	Guía / Guide / Coulisse	64
2	Goma / Rubber / Joint	67
3	Soporte Motor Lateral / Side Motor Support / Support Moteur Latéral	72
4	Embudo / Entry Guide / Tulipe	73
5	Rodamiento / Ball Bearing / Roulement	74
6	Contera / Adjustable Cap / Embout Axe	75
7	Eje / Shaft / Axe	76
8	Tirantes / Springs / Attaches	77
9	Motor Lateral / Side Motor / Moteur Latéral	81

CAJONES

BOXES / COFFRES

■ **Cajón de Aluminio 45°**
45° Aluminium box / Coffre Aluminium 45°

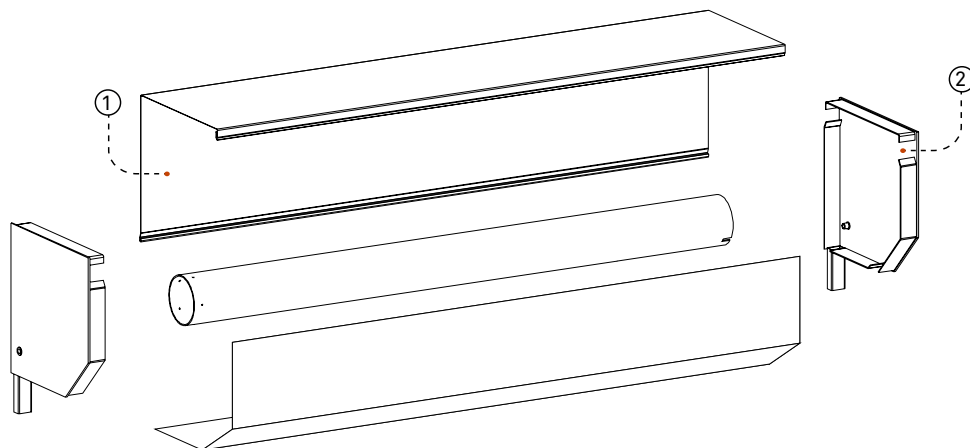

2. Juegos laterales

Pairs of end caps / Jeux consoles

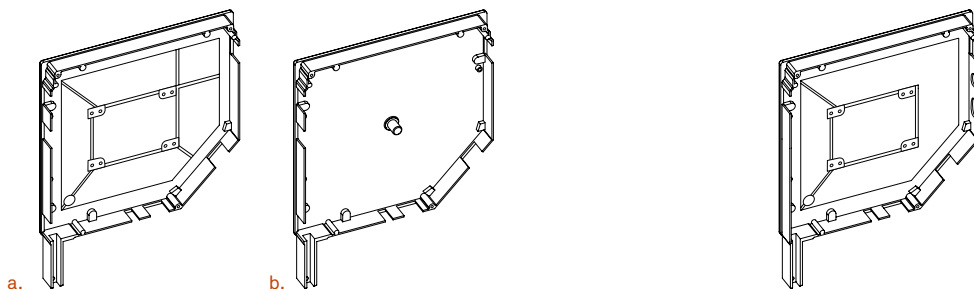

CÓDIGO Code	TAMAÑO Size / Dimension	ARTÍCULOS Articles
a. 160068	250	Jgo Lat c/Al 45° (pata ancha) Pair of end caps alu box 45° (wide p.) Jeu consoles coffre alu 45° (p. large)
b. 160102	250	Jgo Lat c/Al 45° (pata estrecha) Pair of end caps alu box 45° (narrow p.) Jeu consoles coffre alu 45° (p. étroit)

CÓDIGO Code	TAMAÑO Size / Dimension	ARTÍCULOS Articles
160315	250	Jgo. Lateral AL C/AL 45° ZF Pair of alu end caps alu box 45° ZF Jeu consoles alu coffre alu 45° ZF
160317	300	Jgo. Lateral AL C/AL 45° ZF Pair of alu end caps alu box 45° ZF Jeu consoles alu coffre alu 45° ZF

1. Perfiles del cajón

Box profiles / Profils coffre

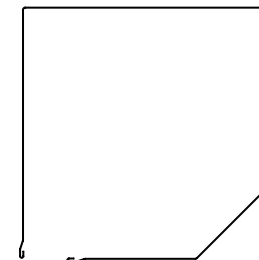

CÓDIGO Code / Código	TAMAÑO Size / Dimension	ARTÍCULOS Articles
332005	250	Cajón Aluminio 45° 2P Aluminium Box 45° 2P Coffre Aluminium 45° 2P
332006	300	
332191	350	
332007	400	

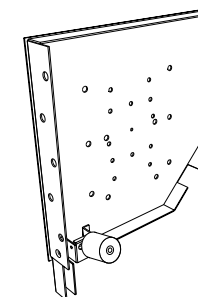
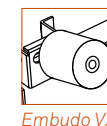

CÓDIGO Code	TAMAÑO Size / Dimension	ARTÍCULOS Articles
160370	300	Jgo Testeros Hierro VX 45° Pair of iron end caps VX 45° Jeu consoles fer VX 45°
160372	350	Jgo Testeros Hierro VX 45° Pair of iron end caps VX 45° Jeu consoles fer VX 45°
160374	400	Jgo Testeros Hierro VX 45° Pair of iron end caps VX 45° Jeu consoles fer VX 45°

* Incluye 160388 Juego Embudos Cajón VX
* 160388 Pair of entry guides VX box included
* L'article 160388 Jeu tulipes coffre VX est inclus

CAJONES

BOXES / COFFRES

■ **Cajón PVC Max**
Max PVC Box / Coffre PVC Max

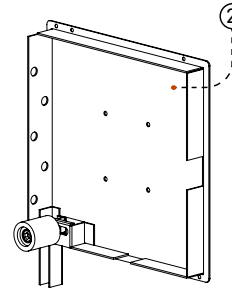
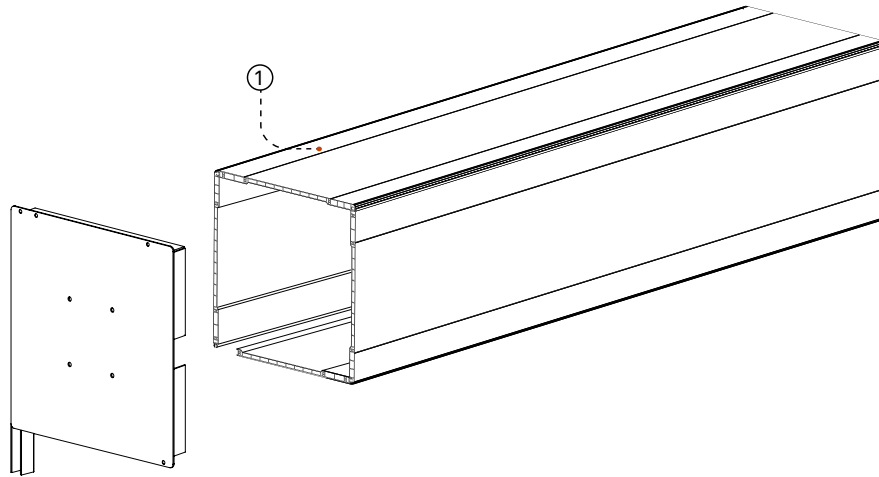

1. Perfiles del cajón

Box profiles / Profils coffre

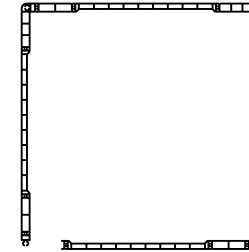

CÓDIGO Code / Código	TAMAÑO Size / Dimension	ARTÍCULOS Articles
333002	275	Cajón PVC Max PVC Max Box
333003	305	Coffre PVC Max

2. Juegos laterales

Pairs of end caps / Jeux consoles

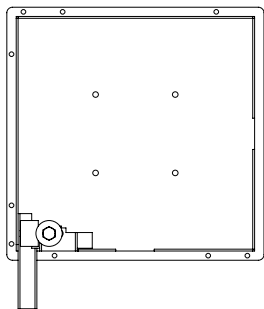

CÓDIGO Code	TAMAÑO Size / Dimension	ARTÍCULOS Articles
116001	275	Jgo Lateral Hierro Cajón Max (pata ancha) Pair of iron end caps Max Box (wide p.)
116005	305	Jeu consoles fer Coffre Max (p. large)
116003	275	Jgo Lateral Hierro Cajón Max (pata estrecha) Pair of iron end caps Max Box (narrow p.)
116007	305	Jeu consoles fer Coffre Max (p. étroit)

CAJONES

BOXES / COFFRES

■ Cajón de Extrusión EXBOX

EXBOX Extruded Aluminium box / Coffre Aluminium Extrudé EXBOX

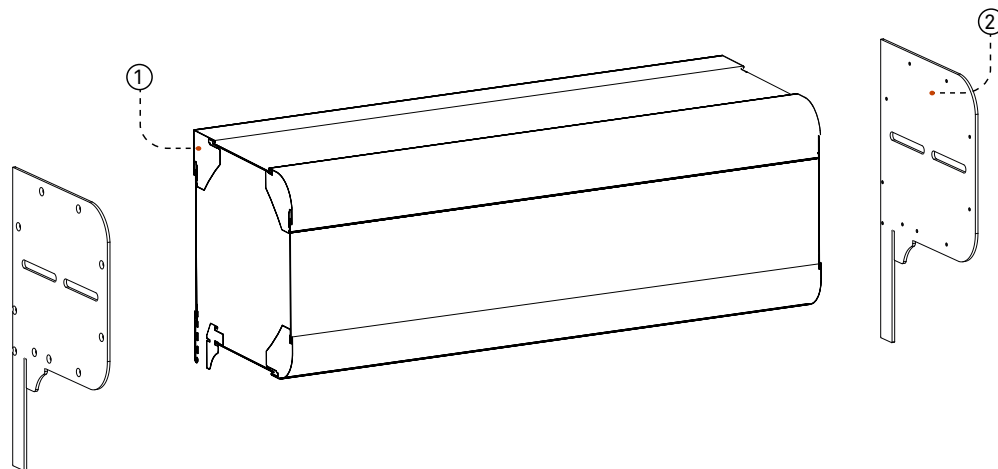

1. Perfiles del cajón

Box profiles / Profils coffre



CÓDIGO Code	ARTÍCULOS Articles
331108	Perfil Esquinero Recto Cajón Exbox Right corner profile of Exbox Box Profil angle droit Coffre Exbox



CÓDIGO Code	ARTÍCULOS Articles
331110	Perfil Esquinero Curvo Cajón Exbox Curved corner profile of Exbox Box Profil angle courbé Coffre Exbox



CÓDIGO Code	ARTÍCULOS Articles
331112	Perfil 68X50.7 Cajón Exbox Profile 68x50.7 of Exbox Box Profil 68x50.7 Coffre Exbox



CÓDIGO Code	ARTÍCULOS Articles
331114	Perfil 85.3X9.5 Cajón Exbox Profile 85.3x9.5 of Exbox Box Profil 85.3x9.5 Coffre Exbox



CÓDIGO Code	ARTÍCULOS Articles
360019	Goma Cajón Exbox Exbox Box Rubber Joint Coffre Exbox



CÓDIGO Code	ARTÍCULOS Articles
160398	Chapa Alu 3000X1250x1 Exbox Aluminium profile 3000x1250x1 Profil aluminium 3000x1250x1

2. Juegos laterales

Pairs of end caps / Jeux consoles

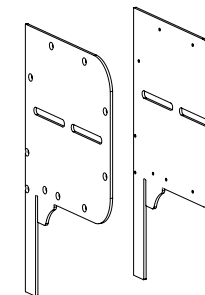

CÓDIGO Code	TAMAÑO Size / Dimension	ARTÍCULOS Articles
160331	300	Jgo Lat Cajón Exbox
160389	350	Pair of end caps Exbox
160333	400	Box
160404	400 / 450	Jeu consoles Coffre
160391	450	Exbox

SOPORTES ESCUADRAS

STEEL SUPPORTS / SUPPORTS ÉQUERRES

■ Soportes Escuadra
Steel supports / Supports équerres

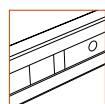
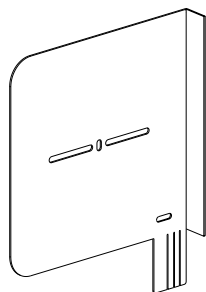
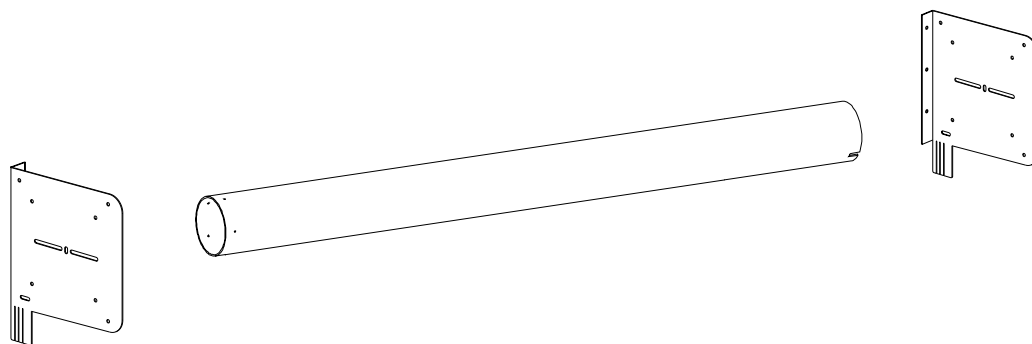

Kit Pletinas

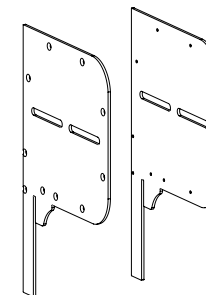
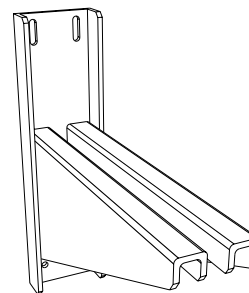
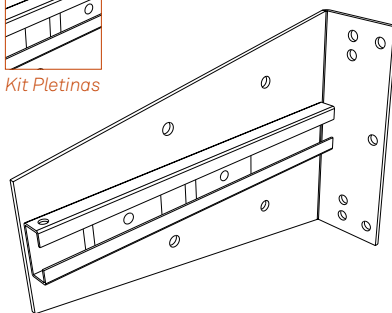

CÓDIGO Code	ARTÍCULOS Articles
160429	Jgo Testeros 400x400 Pata Ajustable Pair of end caps 400x400 adjustable p. Jeu consoles 400x400 p. réglable

CÓDIGO Code	ARTÍCULOS Articles
160323	Soporte Regulable Riel Austral Adjustable bracket Austral rail Support réglable rail Austral
160325	Kit Pletinas Sop. Regulable Rod Axial Platens kit of adjustable sop. axial ball bear. Kit plétines sup. réglable roulement axial

CÓDIGO Code	ARTÍCULOS Articles
160042	Soporte Puertas Motor Lateral Door bracket for side motor Support portes moteur latéral

CÓDIGO Code	TAMAÑO Size / Dimension	ARTÍCULOS Articles
160331	300	Jgo Lat Cajón Exbox
160389	350	Pair of end caps Exbox
160333	400	Box
160391	450	Jeu consoles Coffre Exbox

COMPONENTES

COMPONENTS / COMPOSANTS

■ Embudos

Entry guides / Tulipes

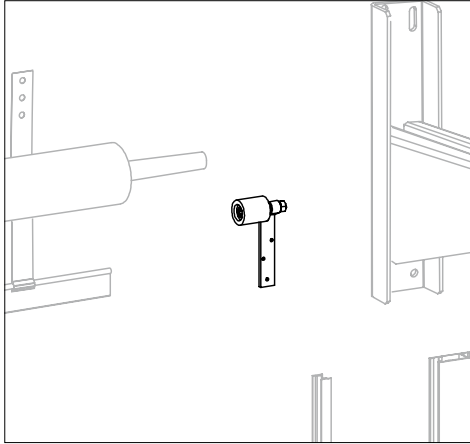

160009 JGO EMBUDOS PUERTA DE GARAJE
 PAIR OF ENTRY GUIDES GARAGE DOOR
 JEU TULIPES PORTE DE GARAGE

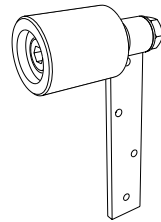

160330 JGO EMBUDOS EXBOX
 PAIR OF ENTRY GUIDES EXBOX
 JEU TULIPES EXBOX

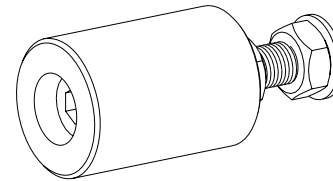

160388 JGO EMBUDOS CAJÓN VX
 PAIR OF ENTRY GUIDES VX BOX
 JEU TULIPES COFFRE VX

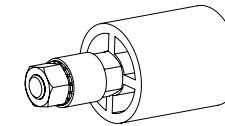

160011 RODILLO NYLON CIERRE 250
 NYLON ROLLER 250 DOOR
 ROULETTE NYLON PORTE 250

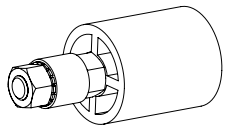

160234 KIT EMBUDO CAJON 250 / 300 45° LAMA 19
 KIT OF ENTRY GUIDE BOX 250/300 45° SLAT 19
 KIT TULIPE COFFRE 250/300 45° LAME 19

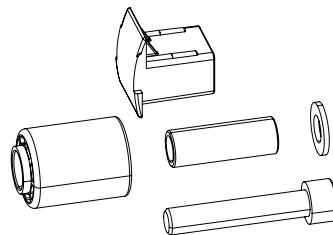

160235 KIT EMBUDO CAJON 250 / 300 45° LAMA 14
 KIT OF ENTRY GUIDE BOX 250/300 45° SLAT 14
 KIT TULIPE COFFRE 250/300 45° LAME 14

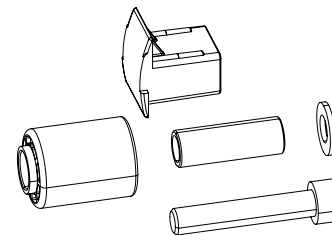

COMPONENTES

COMPONENTS / COMPOSANTS

■ Rodamientos Ball Bearings / Roulements

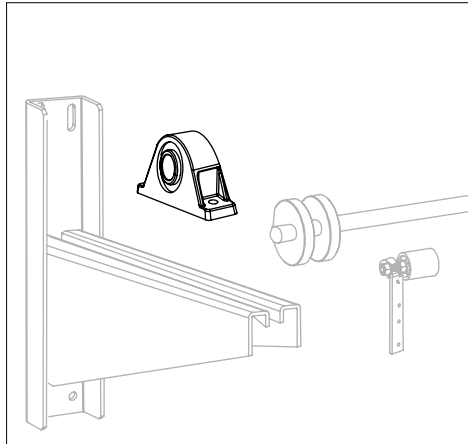

160051 RODAMIENTO PUERTAS ESPIGA 25
DOORS BALL BEARING ROD 25
ROULEMENT PORTES TIGE 25

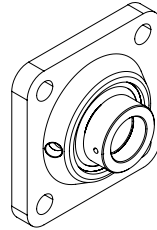

160052 RODAMIENTO PUERTAS ESPIGA 30
DOORS BALL BEARING ROD 30
ROULEMENT PORTES TIGE 30

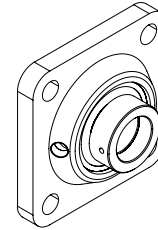

160093 RODAMIENTO ESPIGA DE 12
BALL BEARING ROD 12
ROULEMENT TIGE DE 12

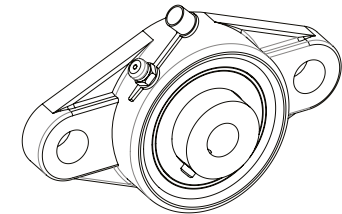

1241121 RODAMIENTO FRONTAL 40MM MOT LAT SDN
FRONT BALL BEARING 40 MM LATERAL MOTOR SDN
ROULEMENT FRONTAL 40 MM MOTEUR LATÉRAL SDN

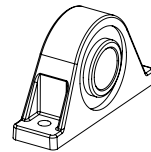

■ Paracaídas Parachutes

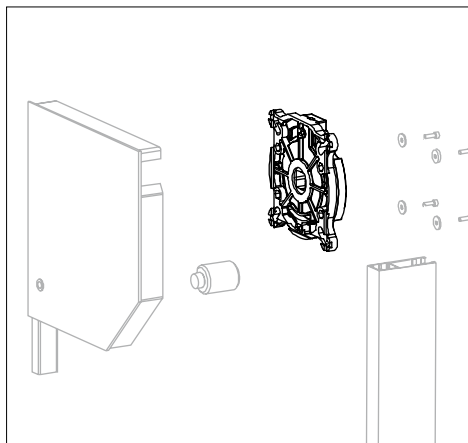

160065 PARACAIDAS 137 NM M2A
PARACHUTES 137 NM M2A
PARACHUTES 137 NM M2A

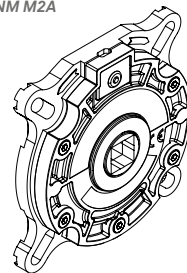

160066 PARACAIDAS 258 NM M3A ESPIGA 25
PARACHUTES 258 NM M3A ROD 25
PARACHUTES 258 NM M3A TIGE 25

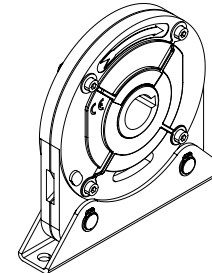

160094 PARACAIDAS 404 NM M4A ESPIGA 30
PARACHUTES 404 NM M4A ROD 30
PARACHUTES 404 NM M4A TIGE 30

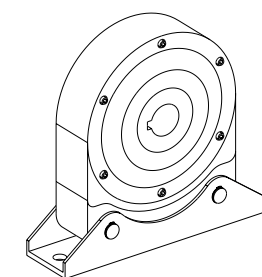

COMPONENTES

COMPONENTS / COMPOSANTS

■ Conteras

Adjustable caps / Embouts axe

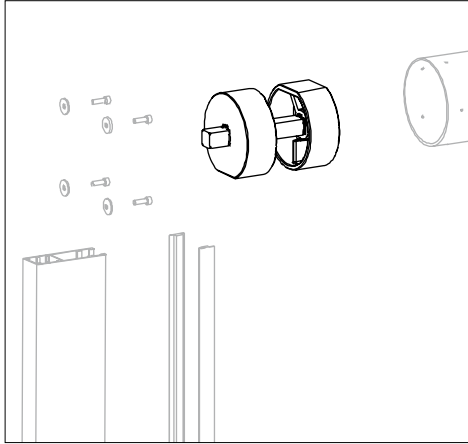

160103 CONTERA MET REG E70 OCT ESP 12
 METALLIC ADJUSTABLE CAP S70 OCT ROD 12
 EMBOUT AXE MÉTALLIQUE RÉGLABLE A70 OCT TIGE 12

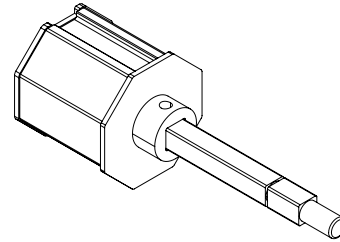

160060 CONTERA ANTICAIDA E70 M2A
 PARACHUTE ADJUSTABLE CAP S70 M2A
 EMBOUT AXE PARACHUTE A70 M2A

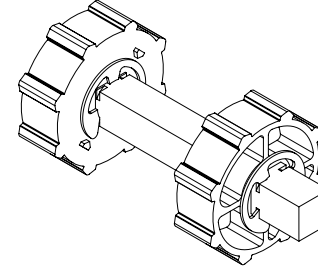

160061 CONTERA ANTICAIDA E100 M2A
 PARACHUTE ADJUSTABLE CAP S100 M2A
 EMBOUT AXE PARACHUTE A100 M2A

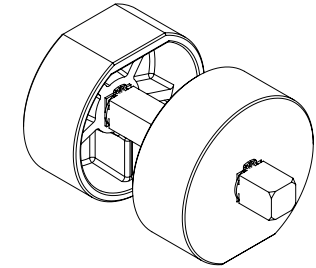

160062 CONTERA MET REG E100 ESP25

160063 CONTERA MET REG E133 ESP25

160064 CONTERA MET REG E133 ESP30

MET ADJUSTABLE CAP (S100ROD25/S133ROD25/S133ROD30)
 EMBOUT AXE MET RÉG (A100TIGE25/A133TIGE25/A133TIGE30)

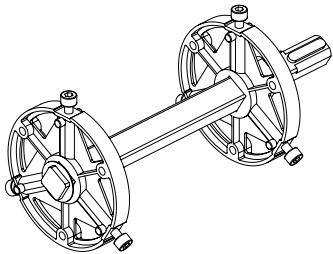

160407 CONTERA ANTICAIDA E100 M4A

160408 CONTERA ANTICAIDA E133 M4A

PARACHUTE ADJUSTABLE CAP M4A (S100/S133)
 EMBOUT AXE PARACHUTE M4A (A100/A133)

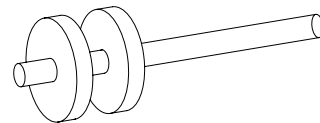

160431 CONTERA ANTICAIDA E100 M3A

160424 CONTERA ANTICAIDA E133 M3A

PARACHUTE ADJUSTABLE CAP M3A (S100/S133)
 EMBOUT AXE PARACHUTE M3A (A100/A133)

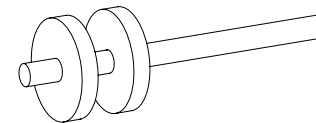

COMPONENTES

COMPONENTS / COMPOSANTS

■ Ejes

Shafts / Axes

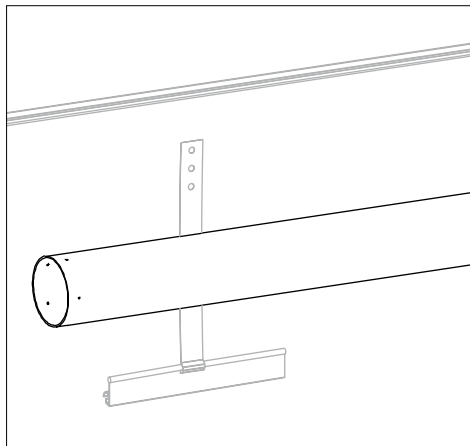

311139 EJE MET REDONDO 60 X 4.0
 ROUND METALLIC SHAFT 60X4.0
 AXE MÉTALLIQUE ROND 60X4.0

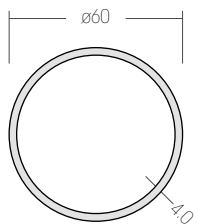

311009 EJE MET OCTOGONAL 70 X 1.2
 OCTOGONAL METALLIC SHAFT 70X1.2
 AXE MÉTALLIQUE OCTOGONAL 70X1.2

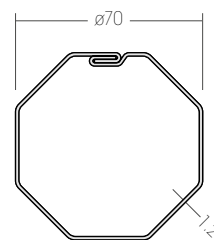

360030 EJE MET REDONDO 100 X 2.0
 ROUND METALLIC SHAFT 100X2.0
 AXE MÉTALLIQUE ROND 100X2.0

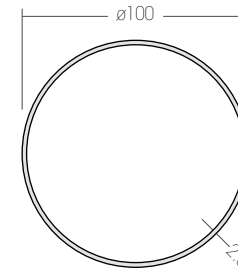

360028 EJE MET REDONDO 133 X 4.0
 ROUND METALLIC SHAFT 133X4.0
 AXE MÉTALLIQUE ROND 133X4.0

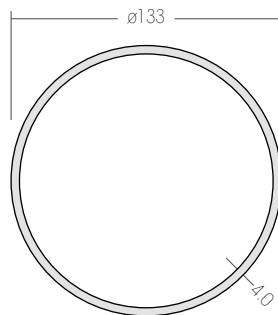

■ Anillos de Adaptación

Adapter Rings / Anneaux d'Adaptation

111001 ANILLO ADAPTACIÓN E100/133
 ADAPTER RING S100/133
 ANNEAU ADAPTATION A100/133

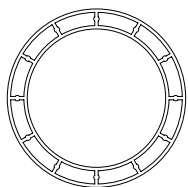

111002 ANILLO ADAPTACIÓN E60/80
 ADAPTER RING S60/80
 ANNEAU ADAPTATION A60/80

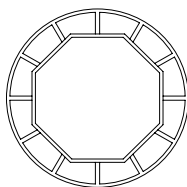

111003 ANILLO ADAPTACIÓN E70/100
111004 ANILLO ADAPTACIÓN E70/80
111494 ANILLO ADAPTACIÓN E70/130
 ADAPTER RING S70/100 - S70/80 - S70/130
 ANNEAU ADAPTATION A70/100 - A70/80 - A70/130

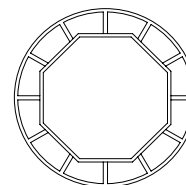

■ Accesorios Ejes

Shaft Accessories / Accessoires Axes

260033 EJE CON MUELLES Y POLEAS A MEDIDA
 SHAFT WITH PULLEYS AND SPRINGS MADE TO MEASURE
 AXE AVEC POULIES ET RESSORTS SUR MESURE



COMPONENTES

COMPONENTS / COMPOSANTS

LAMAS COMPATIBLES
 COMPATIBLE SLATS / LAMES COMPATIBLES

■ **Tirantes**
 Security Springs / Attaches de Sécurité

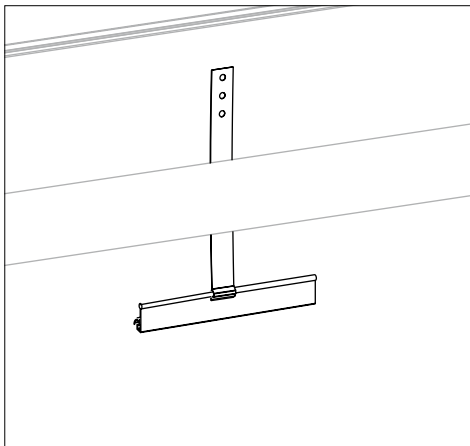

160344 TIRANTE V-100/79/80/77 FLEJE
 SPRING V-100/79/80/77
 ATTACHE V-100/79/80/77

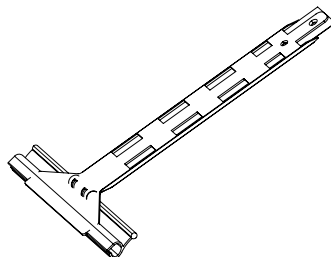

- V-100 Monopared
- V-77 Monopared
- V-77 PF
- V-80 Doble Pared

- V-80 Monopared
- VS-300 Block-95
- VS-350 Block-110

160441 TIRANTE AUTOANCLAJE SEGUR CON FUNDA
 SEGUR SPRING W/COVER
 ATTACHE SEGUR AVEC ÉTUI

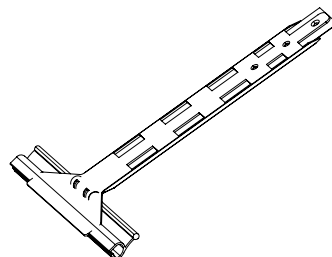

- Segur EC-60
- Segur EC-60 Extreme

160055 TIRANTE ACERO REVEST. VS-150 BLOCK-60
 COATED STEEL SPRING
 ATTACHE ACIER PLAXÉ

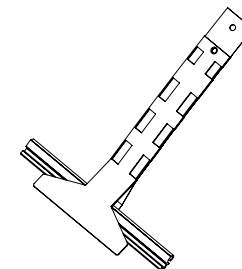

- VS-150 Block-60 Extreme
- VS-150 Block-60

160349 TIRANTE FLEJE VS-300/350/BLOCK 95
 SPRING VS-300/350/BLOCK 95
 ATTACHE VS-300/350/BLOCK 95

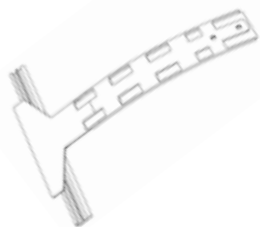

- VS-300 Block-95
- VS-350 Block-110

160233 TIRANTE SEG. BLOQUEO MAXI 2+1
 BLOCKED SECURITY SPRING MAXI 2+1
 ATTACHE DE SÉCURITÉ BLOQ. MAXI 2+1

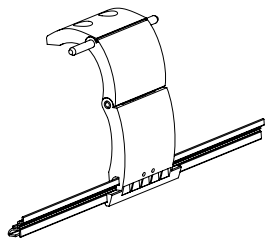

- V-77 PF
- V-100 Monopared

160058 TIRANTE SEGURIDAD MAXI 2+1
 SECURITY SPRING MAXI 2+1
 ATTACHE DE SÉCURITÉ MAXI 2+1

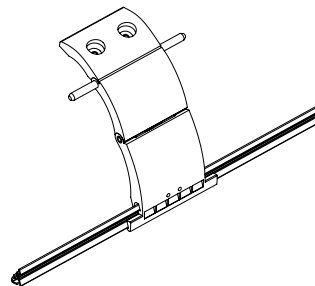

- Segur EC-60

111531 ANILLO TIRANTE SEGURIDAD BLOQUEO E60
111846 ANILLO TIRANTE SEGURIDAD BLOQUEO E70
 BLOCK SECURITY SPRING RING (S60-S70)
 ANNEAU ATTACHE SÉCURITÉ BLOCAGE (A60-A70)

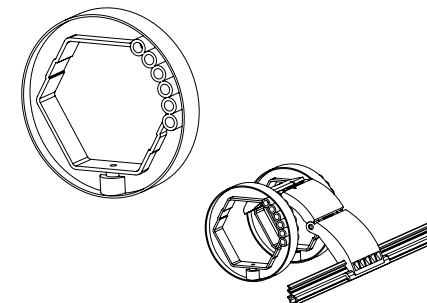

MOTORIZACIÓN

MOTORIZATION / MOTORISATION

■ Motores Tubulares Manuales

Tubular Motors / Moteurs Tubulaires

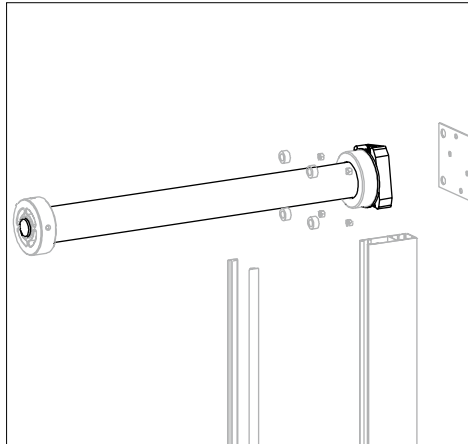

CÓDIGO Code	ARTÍCULOS Articles	NEWTONS	SERIE
124257		50/12 Nm	S45
1241107	MOTOR SPX MANUAL	80/15 Nm	S59
1241108	SPX Manual Override Motor / Moteur SPX Manoeuvre de Secours	100/12 Nm	S59
1241109		120/9 Nm	S59

CÓDIGO Code	ARTÍCULOS Articles	NEWTONS	SERIE
124941		140/12 Nm	S92*
124355	MOTOR SPX MANUAL	230/9 Nm	S92*
124516	SPX Manual Override Motor / Moteur SPX Manoeuvre de Secours	300/9 Nm	S92*



* El uso de este motor implica una diferencia de 4 cm de ancho entre el cajón y el paño.

* The use of this motor imply a difference of 4 cm of width between the roller shutter and the box.

* L'utilisation de ce moteur implique une différence de 4 cm de largeur entre le coffre et le tablier.

MOTORIZACIÓN

MOTORIZATION / MOTORISATION

■ Motores Simu Manuales Mecánicos con maniobra de socorro

Manual Override Simu Motors / Moteurs Simu Manoeuvre de Secours



CÓDIGO Code	ARTÍCULOS Articles	NEWTONS	SERIE
1241045	MOTOR SIMU T8S DMI Simu T8S DMI Motor / Moteur Simu T8S DMI	150 Nm	S94
1241075		200 Nm 220V/60Hz	S94
1241178		200 Nm 110V	S94
1241051		200 Nm	S94
1241076		250 Nm 220V/60Hz	S94
1241085		250 Nm	S94
1241086		300 Nm	S94

CÓDIGO Code	ARTÍCULOS Articles	NEWTONS	SERIE
1241146	MOTOR SIMU T8M Simu T8M Motor / Moteur Simu T8M	300 Nm	S94*
124666		350 Nm	S94*
124825		450 Nm	S94*
1241151	MOTOR SIMU T9M Simu T9M Motor / Moteur Simu T9M	600/9 Nm	-*

CÓDIGO Code	ARTÍCULOS Articles	NEWTONS	SERIE
1241115	SIMU T6M Simu T6 DMI Motor / Moteur Simu T6 DMI	120 / 12 Nm	-
1241139		60 / 12Nm	-
1241140		80 / 12Nm	-
1241141		100 / 12Nm	-

* El uso de este motor implica una diferencia de 4 cm de ancho entre el cajón y el paño.

* The use of this motor imply a difference of 4 cm of width between the roller shutter and the box.

* L'utilisation de ce moteur implique une différence de 4 cm de largeur entre le coffre et le tablier.

■ Motores Simu Mecánicos

Mechanical Simu Motors / Moteurs Simu Mécaniques

CÓDIGO Code	ARTÍCULOS Articles	NEWTONS	SERIE
124524	MOTOR SIMU T8 Simu T8 Motor / Moteur Simu T8	150 Nm	S94
1241149		300 Nm	S94
1241096	MOTOR SIMU T8S Simu T8S Motor / Moteur Simu T8S	150 Nm	S94
1241100		200 Nm 110V	S94
1241097		200 Nm	S94
1241098		250 Nm	S94
1241099		300 Nm	S94



MOTORIZACIÓN

MOTORIZATION / MOTORISATION

■ Motores Centrales

Central Motor / Moteur Central

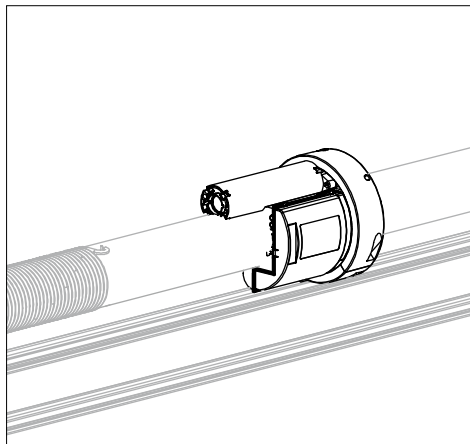

CÓDIGO Code	ARTÍCULOS Articles	NEWTONS	EJE Shaft / Axe
1241154	SIMU CENTRIS	100/10 Nm	60/200
1241132		100/10 Nm	60/220

CÓDIGO Code	ARTÍCULOS Articles	NEWTONS	EJE Shaft / Axe
1241155	SIMU CENTRIS	140/10 Nm	60/220
1241147		200/10 Nm	60/220
1241131		75/10 Nm	60/220

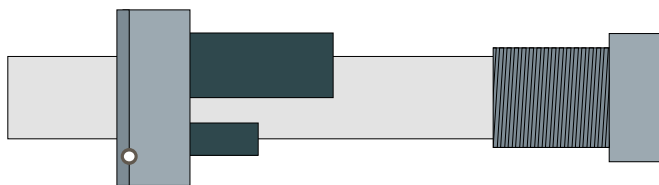

MOTORIZACIÓN

MOTORIZATION / MOTORISATION

■ Motores Laterales

Side Motor / Moteur Latéral

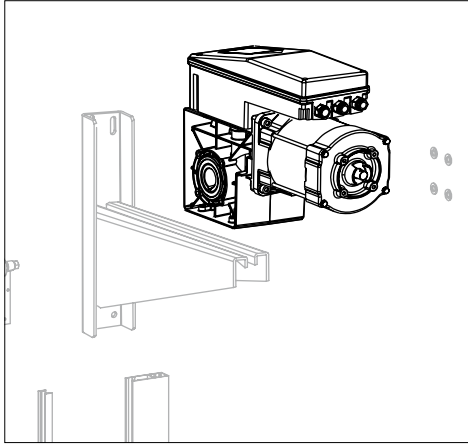

CÓDIGO Code	ARTÍCULOS Articles	NEWTONS
124475	MOTOR LATERAL TRIFASICO CADENA*	250 Nm
124565	Chain Three-Phase Side Motor / Moteur Latéral Triphasé Chaîne	400 Nm

CÓDIGO Code	ARTÍCULOS Articles	NEWTONS
124566	MOTOR LATERAL TRIFASICO*	650 Nm
124567	Three-Phase Side Motor / Moteur Latéral Triphasé	1000 Nm

* Siempre sin cajón y con eje de 100/133

* Always without box and with 100/133 shaft

* Toujours sans coffre et avec axe de 100/133

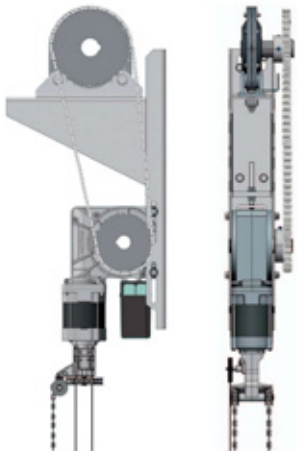

ACCESORIOS MOTORIZACIÓN

MOTORIZATION ACCESSORIES / ACCESSOIRES MOTORISATION

■ Soportes Motores

Motors Brackets / Supports Moteurs

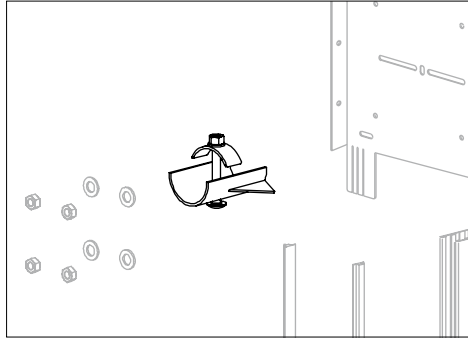

160200 ESCUADRA SUPERIOR SOPORTE MOTOR T8
MOTOR SUPPORT UPPER BRACKET T8
ÉQUERRE SUPERIEURE SUPPORT MOTEUR T8



160202 ESCUADRA INFERIOR SOPORTE MOTOR T8
MOTOR SUPPORT BELOW BRACKET T8
ÉQUERRE INFERIEURE SUPPORT MOTEUR T8



1241050 SOPORTE MOTOR AUSTRAL T8S
AUSTRAL MOTOR BRACKET T8S
SUPPORT MOTEUR AUSTRAL T8S



124347 SOPORTE AUSTRAL T8M/T9M 350/450/600
AUSTRAL BRACKET T8M/T9M 350/450/600
SUPPORT AUSTRAL T8M/T9M 350/450/600



124832 SOPORTE AUSTRAL T8/T9 130/150/250
AUSTRAL BRACKET T8/T9 130/150/250
SUPPORT AUSTRAL T8/T9 130/150/250



124833 SOPORTE AUSTRAL T8/T9 350/450/600
AUSTRAL BRACKET T8/T9 350/450/600
SUPPORT AUSTRAL T8/T9 350/450/600



160393 SOPORTE EJE MUELLES 60 MM.
SHAFT WITH SPRINGS BRACKET 60MM
SUPPORT AXE RESSORTS 60 MM



160040 SOPORTE EJE 60 DE POLEAS
SUPPORT SHAFT
SUPPORT AXE



ACCESORIOS MOTORIZACIÓN

MOTORIZATION ACCESSORIES / ACCESSOIRES MOTORISATION

■ Coronas - Ruedas

Rings - Wheels / Couronnes - Roues

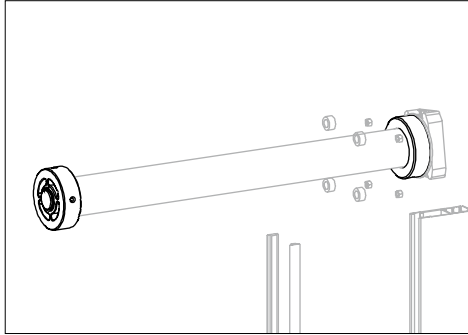

124309 CORONA SPX 70 OCT SERIE 45

124675 RUEDA MOTRIZ SPX 70 OCT SERIE 45

RING - DRIVE WHEEL SPX 70 OCT SERIE 45
COURONNE - ROUE MOTRICE SPX 70 OCT SÉRIE 45



124322 CORONA SPX 70 OCT SERIE 59

124676 RUEDA MOTRIZ SPX 70 OCT SERIE 59

RING - DRIVE WHEEL SPX 70 OCT SERIE 59
COURONNE - ROUE MOTRICE SPX 70 OCT SÉRIE 59



124323 CORONA SPX 100 RED SERIE 59

124677 RUEDA MOTRIZ SPX 100 RED S.59

RING - DRIVE WHEEL SPX 100 RED SERIE 59
COURONNE - ROUE MOTRICE SPX 100 RED SÉRIE 59



124324 CORONA SPX 100 RED SERIE 92

124678 RUEDA MOTRIZ SPX 100 RED S.92

RING - DRIVE WHEEL SPX 100 RED SERIE 92
COURONNE - ROUE MOTRICE SPX 100 RED SÉRIE 92



124680 CORONA SPX 133 RED SERIE 92

124681 RUEDA MOTRIZ SPX 133 SERIE 92

RING - DRIVE WHEEL SPX 133 RED SERIE 92
COURONNE - ROUE MOTRICE SPX 133 RED SÉRIE 92



1241081 CORONA SPX 64 ZF SERIE 45

1241082 RUEDA MOTRIZ SPX 64 SERIE 45

RING - DRIVE WHEEL SPX 64 ZF SERIE 45
COURONNE - ROUE MOTRICE SPX 64 ZF SÉRIE 45



1241083 CORONA SPX 80 ZF SERIE 45

1241084 RUEDA MOTRIZ SPX 80 SERIE 45

RING - DRIVE WHEEL SPX 80 ZF SERIE 45
COURONNE - ROUE MOTRICE SPX 80 ZF SÉRIE 45



1241119 CORONA SPX 80 ZF SERIE 59

1241120 RUEDA MOTRIZ SPX 80 SERIE 59

RING - DRIVE WHEEL SPX 80 ZF SERIE 59
COURONNE - ROUE MOTRICE SPX 80 ZF SÉRIE 59



124831 CORONA-RUEDA ADAPT SIMU T8 100 RED S95

WHEEL ADAPTER CROWN SIMU T8 100 RED S95
COURONNE-ROUE ADAPTATION SIMU T8 100 RED S95



124665 CORONA-RUEDA ADAPT SIMU T8 100 RED S94

WHEEL ADAPTER CROWN SIMU T8 100 RED S94
COURONNE-ROUE ADAPTATION SIMU T8 100 RED S94



1241114 CORONA-RUEDA AD. SIMU T8 133 RED S124

WHEEL ADAPTER CROWN SIMU T8 133 RED S124
COURONNE-ROUE ADAPTATION SIMU T8 133 RED S124



ACCESORIOS MOTORIZACIÓN

MOTORIZATION ACCESSORIES / ACCESSOIRES MOTORISATION

■ Snodos y Manivelas

Hand cranks and Cranks /
Manivèles et Genouillères

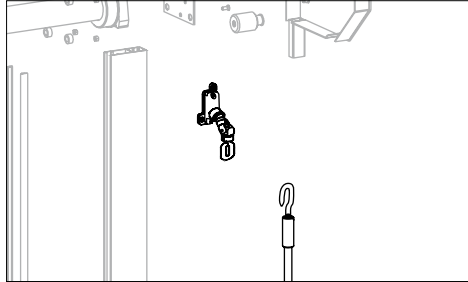

SISTEMA PÉNDULO PENDULUM SYSTEM / SYSTÈME PENDULE

111830 SNODO 90° FJ PENDULO P/MET.
90° PENDULUM GEAR MECHANISM FJ
GENOUILLEÈRE 90° FJ PENDULE



111886 MANIVELA CARDAN FJ CAMPANA
HAND CRANK GEAR MECHANISM FJ W/BELL
MANIVÈLE TREUIL FJ A/CLOCHE



SISTEMA IMÁN MAGNET SYSTEM / SYSTÈME AIMANT

111799 SNODO MT12 E-7 L380 90°
GEAR MECHANISM MT12 E-7 L380 90°
GENOUILLEÈRE TREUIL MT12 E-7 L380 90°



111722 REDUCCIÓN MAG. SNODO MT12
MAG. REDUCTION GEAR MECHANISM MT12
RÉDUCTION MAG. GENOUILLEÈRE MT12



111308 SNODO 45° P/CIERRE VARILLA 300
GEAR MECHANISM 45° P/CLOSING ROD 300 MM
GENOUILLEÈRE 45° P/FERMETURE TIGE 300



111783 MANIVELA CAR MT12 ART D13 INTER. 100 L235
111800 MANIVELA CAR MT12 ART D15 INTER. 140 L150
111657 MANIVELA CAR MT12 ART D13 INTER. 180 L150
HAND CRANK GEAR MT12 ARTICULATED
MANIVÈLE TREUIL MT12 ARTICULÉE



SISTEMA INVISIBLE INVISIBLE SYSTEM / SYSTÈME INVISIBLE

160224 SNODO INVISIBLE L350
INVISIBLE GEAR MECHANISM L350
GENOUILLEÈRE INVISIBLE L350



160226 MANIVELA SNODO INVISIBLE L1200
HAND CRANK INVISIBLE GEAR L1200
MANIVÈLE GENOUILLEÈRE INVISIBLE L1200



ACCESORIOS MOTORIZACIÓN

MOTORIZATION ACCESSORIES / ACCESSOIRES MOTORISATION

SISTEMA ANILLO RING SYSTEM / SYSTÈME ANNEAU

180346 MANIVELA GANCHO 1.20
HAND CRANK HOOK 1.20
MANIVÈLE CROCHET 1.20



124958 SNODO C/ANILLA SPX SERIE 45/59
GEAR MECHANISM WITH RING SPX SERIE 45/59
GENOUILLÈRE AVEC ANNEAU SPX SÉRIE 45/59



111534 SNODO 45° P/MET 2 T VARILLA HEX.
GEAR MECHANISM 45° P/MET 2 DRILLS HEXA ROD
GENOUILLÈRE 45° P/MET 2 FORETS TIGE HEXA



124959 SNODO C/ANILLA SPX SERIE 92.
GEAR MECHANISM WITH RING SPX SERIE 92
GENOUILLÈRE AVEC ANNEAU SPX SÉRIE 92



180028 VARILLA HEX 7MM C/ANILLA AUSTRAL.
HEX ROD 7MM WITH RING AUSTRAL
TIGE HEX 7MM AVEC ANNEAU AUSTRAL



160010 AD. MANIVELA MOTOR DESPL. CAJÓN 300
160028 AD. MANIVELA MOTOR DESPL. CAJÓN 400.
HAND CRANK AD. DISPL. MOTOR 300 - 400 BOX
ADAPT. MANIVÈLE MOT. DÉPL. COFFRE 300 - 400



■ Automatismos Automatismes / Automatismes

1241048 RECEPTOR PUERTA HOMBRE PRESENTE.
DEAD MAN DOOR RECEIVER
RÉCEPTEUR PORTE HOMME PRÉSENT



1241194 KIT SISTEMA SEGURIDAD.
KIT OF SECURITY SYSTEM
KIT SYSTÈME SÉCURITÉ



1241195 EMISOR MUV 2C.
MUV 2C REMOTE
ÉMETTEUR MUV 2C



ACCESORIOS MOTORIZACIÓN

MOTORIZATION ACCESSORIES / ACCESSOIRES MOTORISATION

■ Automatismos

Automatismes / Automatismes

124445 RECEPTOR PUERTA TRIFASICO

THREE-PHASE DOOR RECEIVER
RÉCEPTEUR PORTE TRIPHASÉ



1241196 TECLADO NUMERICO VIA RADIO

WIRELESS KEYBOARD
CLAVIER NUMÉRIQUE VIA RADIO



1241049 EMISOR PUERTA 2 OP HP

DOOR REMOTE 2 OP DM
ÉMETTEUR PORTE 2 OP HP



1241172 EMISOR PUERTA 4 OP HP

DOOR REMOTE 4 OP DM
ÉMETTEUR PORTE 4 OP HP



124035 INVERSOR A LLAVE EXTERIOR EMPOTRAR

OUTSIDE EMBEDDED SWITCH WITH KEY
INVERSEUR EXTÉRIEUR À CLÉ MONTAGE ENCASTRÉ



124036 INVERSOR A LLAVE EXTERIOR SUPERFICIE

OUTSIDE SURFACE SWITCH WITH KEY
INVERSEUR EXTÉRIEUR À CLÉ MONTAGE EN SURFACE



124439 INVERSOR A LLAVE SUPERFICIE RADIO

SURFACE OUTSIDE RADIO SWITCH WITH KEY
INVERSEUR À CLÉ MONTAGE SURFACE RADIO



124583 INVERSOR A LLAVE EMPOTRAR RADIO

EMBEDDED OUTSIDE RADIO SWITCH WITH KEY
INVERSEUR À CLÉ MONTAGE ENCASTRÉ RADIO



124038 INVERSOR

SWITCH
INVERSEUR



1241174 FOTOCELULA SUPERFICIE SINCRONIZADA

SURFACE PHOTOCELL SYNCHRONIZED
PHOTOCELLULE SURFACE SYNCHRONISÉE



1241175 FOTOCELULA CATADIOPTRICA ESPEJO

PHOTOCELL MIRROR
PHOTOCELLULE MIROIR



ACCESORIOS MOTORIZACIÓN

MOTORIZATION ACCESSORIES / ACCESSOIRES MOTORISATION

■ Accesorios de Seguridad

Security accessories / Accessoires de sécurité

160087 TAQUILLA DESBLOQUEO EXTERIOR

OUTSIDE UNBLOCKING LOCKER
CASIER DE DÉBLOCAGE EXTÉRIEUR



160469 TAQUILLA GUIA CON BOMBIN EUROPEO

UNBLOCKING GUIDE LOCKER (SWITCH)
CASIER COULISSE DE DÉBLOCAGE (INTERRUPTEUR)

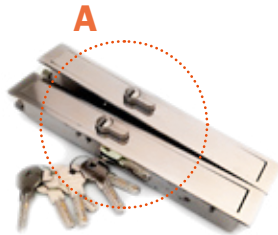

160470 KIT CERRADURA Y TAQUILLA GUIA CON BOMBIN EUROPEO

UNBLOCKING GUIDE LOCKER (SWITCH)
CASIER COULISSE DE DÉBLOCAGE (INTERRUPTEUR)

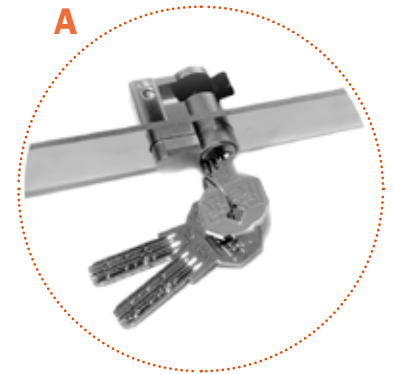

160468 CERRADURA BOMBIN EUROPEO LLAVES DIFERENTES

CENTRAL LOCK 2 BOLTS
SERRURE CENTRALE 2 GOUPILLES

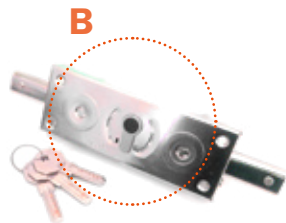

160482 CERRADURA BOMBIN EUROPEO LLAVES IGUALES

FINAL LOCK SAME KEYS
SERRURE FINALE CLÉS SIMILAIRES

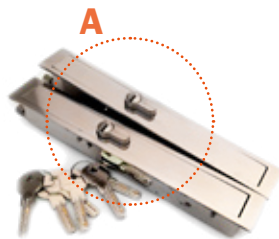

160299 TOPE CUÑA PUERTA

DOOR STOPPER
ARRÊTOIR PORTE

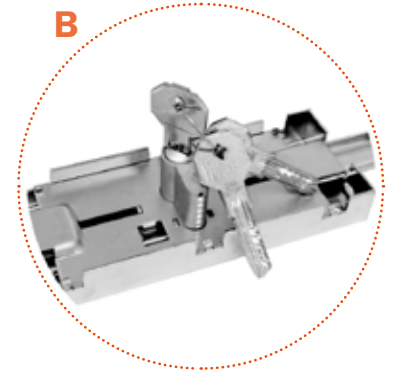

PERSAX®

siente el espacio

OFICINAS CENTRALES

Persianas Persax, S.A. · Autovía A-31 (salida 191) · 03400 Villena (Alicante) ESPAÑA
T. 902 010 564 · T. 965 817 520 · T. Export. +34 965 272 444 - F. 902 010 565 · F. Export. +34 965 340 722
central@persax.es · export@persax.es · www.persax.es

DELEGACIONES NACIONALES

Sevilla - T. 955 852 512 - F. 955 852 768 - sevilla@persax.es
Huelva - T. 959 356 031 - F. 959 367 995 - huelva@persax.es
Zaragoza - T. 976 855 336 - T. 976 854 833 - F. 976 859 161 - aragon@persax.es
Palencia - T. 979 713 360 - F. 979 711 601 - castillayleon@persax.es

FILIALES INTERNACIONALES

México - T. (669) 105.5010 - direccion@persax.mx / www.persax.mx
Croacia - T. +385 1 3353500 - info@persax.hr / www.persax.hr

